

245788

8332251

002-47-2292

NOTICE: PORTIONS OF THIS
DECLARATION AND MASTER DEED
ARE SUBJECT TO THE TEXAS
GENERAL ARBITRATION ACT

DECLARATION AND MASTER DEED
PONDEROSA FOREST CONDOMINIUMS
GALVESTON COUNTY, TEXAS

SUMMARY OF CONTENTS

ARTICLE I.	DEFINITIONS
ARTICLE II.	DIVISION OF PROPERTY AND CREATION OF PROPERTY RIGHTS
ARTICLE III.	ASSOCIATION, ADMINISTRATION, MEMBERSHIP AND VOTING RIGHTS
ARTICLE IV.	MAINTENANCE AND ASSESSMENTS
ARTICLE V.	DUTIES AND POWERS OF THE ASSOCIATION
ARTICLE VI.	UTILITIES
ARTICLE VII.	USE RESTRICTIONS
ARTICLE VIII.	ARCHITECTURAL CONTROL
ARTICLE IX.	GENERAL PROVISIONS

002-47-2293

DECLARATION AND MASTER DEED

PONDEROSA FOREST CONDOMINIUMS

Galveston County, Texas

THIS DECLARATION AND MASTER DEED ("Declaration"), made on the date hereinafter set forth by PONDEROSA FOREST, INC., a Texas corporation ("Declarant"), is made with reference to the following facts:

A. Declarant is the owner of certain improved real property located in the City of Dickinson, County of Galveston, State of Texas, more particularly described on Exhibits "A", "E" and "F" attached hereto and by this reference made a part hereof.

B. The Property presently subject to this Declaration consists of the land described on Exhibit "E", two (2) residential buildings containing a total of twenty-eight (28) Units therein, together with other improvements now or hereafter erected thereon, facilities and appurtenances thereto and all personal property, intended for use or used in connection with the Property, being hereinafter sometimes collectively referred to as the "Project" or the "Condominiums."

C. Declarant desires to establish a condominium regime under the Texas Condominium Act. Declarant does hereby establish a plan for the individual ownership in fee simple of estates consisting of the Unit plus an undivided interest as tenant in common in the Common Elements. Each Unit shall have appurtenant to it a membership in PONDEROSA FOREST HOMEOWNERS ASSOCIATION, INC.

D. Declarant intends by this document to impose upon the Property mutually beneficial restrictions under a general plan of improvements for the benefit of all of said Condominiums and the Owners thereof.

Declarant does hereby establish PONDEROSA FOREST CONDOMINIUMS as a condominium regime under the Texas Condominium Act and hereby declares that the Condominiums shall be held, conveyed, mortgaged, encumbered, leased, rented, used, occupied, sold and improved subject to the following declarations, limitations, covenants, conditions, restrictions and easements, all of which are for the purpose of enhancing and protecting the value and attractiveness of the Project and every part thereof.

002-47-2294

All of the limitations, covenants, conditions, restrictions and easements shall constitute covenants which shall run with the land and shall be perpetually binding upon Declarant and its successors-in-interest and assigns, and all parties having or acquiring any right, title or interest in or to any part of the Project.

ARTICLE I.

DEFINITIONS

1.1 "Articles" shall mean and refer to the Articles of Incorporation of the Association as amended from time to time.

1.2 "Assessment" shall mean the assessment made and levied against each Owner and his Unit for that portion of the cost of maintaining, improving, repairing, operating and managing the Condominiums and for repair, maintenance and operation of the Common Elements, including reserves for replacements, which is to be paid by each Unit Owner as determined by the Association in accordance with this Declaration and the Bylaws.

1.3 "Association" shall mean and refer to the PONDEROSA FOREST HOMEOWNERS ASSOCIATION, INC., its successors and assigns, a non-profit corporation organized pursuant to the Texas Non-Profit Corporation Act, of which the Owners shall all be Members. The term "Association" shall have the same meaning as the term "Council of Co-Owners" in the Texas Condominium Act.

1.4 "Board" or "Board of Directors" shall mean and refer to the governing body of the Association.

1.5 "Bylaws" shall mean and refer to the Bylaws of the Association as amended from time to time.

1.6 "Common Elements" shall mean and refer to both the General Common Elements and Limited Common Elements described herein.

1.7 "Common Expenses" means and includes:

1.7.1 All sums lawfully assessed with respect to the Common Elements by the Board;

1.7.2 Expenses of administration and management, maintenance, repair or replacement of the Common Elements, as provided herein, including a reasonable reserve for such purposes;

1.7.3 Expenses agreed upon as Common Expenses by the Owners; and

002-47-2295

1.7.4 All sums designated as Common Expenses by or pursuant to the Project Documents.

1.8 "Common Interest" means the proportionate undivided percentage interest in the Common Elements which is appurtenant to each Unit as set forth in this Declaration.

1.9 "Condominium" or "Unit" shall mean one individual unit, together with its undivided percentage interest in the Common Elements. The term "Condominium" or "Unit" shall have the same meaning as the term "apartment" as used in the Texas Condominium Act.

1.10 "Building" shall mean one or more of the structures erected on the Property containing two or more Units.

1.11 "Declarant" shall mean and refer to PONDEROSA FOREST, INC., and its successors-in-interest and assigns, provided such successors or assigns are designated in writing by Declarant as a successor or assign of the rights of Declarant hereunder.

1.12 "Declaration" shall mean and refer to this enabling Declaration.

1.13 "General Common Elements" shall mean and include:

1.13.1 The land in the condominium regime as more particularly described on Exhibits "E" and "F" attached hereto or as amended from time to time pursuant to this Declaration;

1.13.2 To the extent not otherwise designated as Limited Common Elements, the foundations, common dividing walls between two or more Units or between Units and Common Elements, exterior walls, bearing walls and columns (including any windows, doors and chimneys therein), girders, beams, slabs, supports, roofs, attics, ceilings and floors, halls, lobbies, or thoroughfares such as stairways, entrances, exits or communication ways and any other portion of any Building located on the Property;

1.13.3 The grounds, yards, gardens, swimming pools, clubrooms, managerial offices, mail rooms, unassigned parking areas, driveways, fences, unassigned storage areas, streets, service drives, walks, service easements, recreational common facilities, laundry rooms, boiler rooms, mechanical rooms, and areas used for storage of maintenance and janitorial equipment and materials, if any;

1.13.4 The installations consisting of the equipment and materials making up central services such as power, electricity, gas, water, sewer, television, hot water, and the like which are intended to serve more than one Unit; elevator, elevator shafts, machinery and equipment related thereto;

002-47-2296

1.13.5 Parking spaces not yet designated with a corresponding Unit number and described on the Map attached hereto as visitor parking spaces; provided, however, that Declarant expressly reserves the right for itself and/or the Board of Directors at any time and from time to time to assign and to reassign parking spaces to Owners; and provided further, coincidental with the assignment or reassignment of any parking space, or after the assignment of all unassigned parking spaces, the Map attached hereto may be amended without the consent of any Owner for the purpose of designating any such parking space with a number corresponding to the Unit number, and thereafter such parking space shall be a Limited Common Element appurtenant to such Unit, subject to the right to reassign granted herein.

1.13.6 All other structures, facilities, equipment, and property located on the Project necessary or convenient to its existence, maintenance, operation and safety, or normally in common use.

1.13.7 All other items not described as a Unit or a Limited Common Element.

1.13.8 All repairs, replacements and additions to any of the foregoing.

1.14 "Institutional Lender" shall mean the Federal Home Loan Mortgage Corporation, the Federal National Mortgage Association or other similar government agency; any bank, savings and loan association, insurance company or other similar financial institution holding a recorded first Mortgage or Deed of Trust on any Unit.

1.15 "Limited Common Elements" shall mean those Common Elements reserved for the use of a specified Unit or Units to the exclusion of others, or serving exclusively one or more specified Units, the enjoyment, benefit or use of which is reserved to the lawful occupants of said Unit either in this Declaration, or as indicated on the Map as same may be amended from time to time, including by way of example, but not limited to:

1.15.1 Parking spaces once assigned and designated with a Unit number in accordance with Section 1.13.5 hereof, subject to the right to reassign granted therein;

1.15.2 Patios, balconies, entrances, stairways and storage areas, if any, indicated on the Map as Limited Common Elements appurtenant to a specified Unit or Units;

1.15.3 The utilities, sewers, power, water, gas, electricity and other common lines running through the walls, ceiling or floors of each Unit and used only to service such Unit.

002-47-2297

1.15.4 Such portions of the perimeter walls, floors, ceilings, doors, windows, and all associated fixtures and structures therein, as lie outside the Unit boundaries but that serve only such Unit.

1.16 "Map" or "Condominium Plan" shall mean and refer to the engineering survey of the Property which is legally described in Exhibit "B", said Map being filed herewith as Exhibit "B" and by this reference made a part hereof, as the same may be amended from time to time as herein provided. The Map sets forth, among other things, a survey of the Property showing the location of each Building designated by a letter, a general description and plat of each Unit showing its square footage, Building location, floor and Unit number and a general description of the Common Elements.

The Map contains the certificate of a registered professional engineer or registered public surveyor that the Map substantially depicts the results of an on the ground survey. In interpreting the Map, the existing physical boundaries of each Unit shall be conclusively presumed to be its boundaries. Declarant reserves unto itself the right, so long as Declarant owns one or more Units, to amend the Map and amendments thereto to conform same to the actual location of any of the improvements; to establish, vacate and relocate easements, access road easements and parking spaces; to establish certain General Common Elements not theretofore established; to establish certain General Common Elements as Limited Common Elements; and to show such other changes that Declarant may make in accordance with the terms of this Declaration including, but not limited to, Section 2.3.

1.17 "Member" shall mean and refer to a person entitled to membership in the Association as provided herein.

1.18 "Mortgage" or "Deed of Trust" shall mean a lien interest in a Unit given to a creditor as security for repayment of a loan made to the Unit Owner, said interest to be evidenced by an instrument duly and properly recorded in the Deed of Trust Records of Galveston County, Texas.

1.19 "Mortgagee" shall mean the beneficiary or a holder of any first lien Deed of Trust or first Mortgage.

1.20 "Owner" or "Owners" shall mean and refer to the record holder or holders of fee simple title of a Unit in the Project, but shall exclude Persons having any interest in a Unit merely as security for the performance of any obligation.

002-47-2298

1.21 "Person" means a natural person, a corporation, a partnership, association, trust, or other legal entity.

1.22 "Project Documents" means and includes this Declaration and the exhibits attached hereto, the Articles and Bylaws of the Association and the rules and regulations for the Members, as the same may be established or amended from time to time.

1.23 "Texas Condominium Act" or "Act" shall mean Article 1301a of the Texas Revised Civil Statutes, enacted in 1963, which permits the creation of condominium regimes, as same is amended or supplemented in any successor statute.

ARTICLE II

DIVISION OF PROJECT AND

CREATION OF PROPERTY RIGHTS

2.1 Division of Project The Project is hereby divided into the following freehold estates and areas: On the Map attached hereto, the Buildings in the Project are lettered "A" through "H" and the Units located therein are numbered as shown on the Map.

2.1.1 Units In determining dimensions of, and area contained within each Unit, the enclosed space within a Unit shall be measured from interior finished, unpainted surfaces of the perimeter walls, floors and ceilings, and the Unit shall include the airspace so encompassed. Included in each Unit, without limitation, shall be any finishing materials applied or affixed to the interior surfaces of the common exterior walls or interior walls, floors or ceilings (such as, but without limitation, paint, wallpaper, vinyl wall or floor covering, carpet and tile). The boundaries of each Unit shall be the interior surface of the perimeter walls, floors, ceilings, windows and doors. Interior trim around windows and doors shall be a part of each Unit and shall not be a part of the Common Elements. For the purposes of Article II the Unit does not include "Common Elements" defined herein. It is expressly stipulated, and each and every purchaser of a Unit, his heirs, executors, administrators, successors and assigns hereby agree that the square footage, size and dimensions of each Unit, as set out and shown in this Declaration or on the Condominium Plan are approximate and are shown for descriptive purposes only, and that the Declarant does not warrant, represent or guarantee that any Unit actually contains the area, square footage or dimensions shown by the Condominium Plan thereof. Each purchaser and Owner of a Unit, or interest therein, has had full opportunity and is under a duty to inspect and examine the Unit purchased by him prior to the purchase thereof, and agrees that the Unit is purchased as actually and physically existing. Each purchaser of a Unit hereby expressly waives any claim or

002-47-2299

demand which he may have against the Declarant or other seller of such Unit on account of any difference, shortage or discrepancy between the Unit as actually and physically existing and as it is shown on the Condominium Plan. Each Unit is subject to such encroachments and protrusions as are contained in each Building, whether the same now exist or may be later caused or created in any manner. In interpreting deeds and the Condominium Plan, the term existing physical boundaries of a Unit, whether in its original state or reconstructed in substantial accordance with the original plans thereof, shall be conclusively presumed to be its boundaries rather than the boundaries expressed in the deed or Condominium Plan, regardless of settling, rising or lateral movement of any Building and regardless of minor variance between boundaries shown on the Condominium Plan or deed, and those of any Building.

2.1.2 Common Elements The remaining portion of the Property, referred to herein as "Common Elements" shall include all of the elements set forth in Section 1.6. Each Unit shall have as an appurtenance to it an undivided percentage interest in the Common Elements, based upon the approximate size of the Unit in relation to the others, as set forth in Exhibit "C" attached hereto and by this reference made a part hereof. The ownership of each Condominium shall include a Unit and such undivided percentage interest in the Common Elements. Such Common Interest cannot be separated from the Unit to which it is appurtenant. Each Unit Owner shall have a non-exclusive right to use the General Common Elements in accordance with the purposes for which they are intended without hindering the exercise of or encroaching upon the rights of any other Unit Owners. Notwithstanding the transfer of the ownership of the Common Elements to the Owners as tenants in common, the Declarant shall reserve and hereby reserves unto itself and to the Association or its designated agents an easement over and onto the Common Elements for common driveway purposes, for drainage and encroachment purposes and for ingress to and egress from the Common Elements for the purpose of completing improvements thereon and for the performance of necessary repair work. Declarant further reserves unto itself and to the Association or its designated agents the right to establish easements, reservations, exceptions and exclusions consistent with the ownership of the Condominium Project and for the best interest of the Owners and the Association in order to serve the entire Condominium Project.

002-47-2300

2.1.3 Limited Common Elements The Limited Common Elements shall be identified herein or on the Map, as amended from time to time, and designated as appurtenant to a particular Unit or Units. The rights of an individual Owner in the Limited Common Elements shall consist of (1) an exclusive easement to use for vehicle parking purposes, the parking space or spaces specifically originally assigned or reassigned by Declarant or the Association to the Owner as being appurtenant to his Unit, if any; (2) an exclusive easement to use the utilities and lines described in Section 1.15.3 and the areas described in Section 1.15.4; (3) an exclusive easement for ingress and egress over and for the use and enjoyment of the exterior stairs and landing area adjacent and appurtenant to the Unit (provided, however, that such easement shall be shared with any other Unit to which such stairs and landing area are also adjacent and appurtenant), if any; (4) an exclusive easement to use a storage area, balcony or patio, if any, adjacent to and appurtenant to the Unit, as shown on the Condominium Plan; and (5) an exclusive easement to use such other areas and facilities as may be designated in this Declaration and on the Map, as same may be amended from time to time.

2.2 No Separate Conveyance of Undivided Interests The foregoing interests and exclusive easements are hereby established and are to be conveyed only with the respective Units, and cannot be changed, except as herein set forth. Declarant and each Owner covenant and agree that the undivided interests in the Common Elements, the exclusive easements of the Limited Common Elements, and the fee title to the respective Units conveyed therewith, shall not be separated or separately conveyed, and each such undivided interest and exclusive easement shall be deemed to be conveyed or encumbered with its respective Unit even though the description in the instrument of conveyance or encumbrance may refer only to the fee title to the Unit.

2.3 Partition Prohibited The Common Elements shall remain undivided as set forth above so long as suitable for a condominium regime. Except as provided by the Texas Condominium Act, no Owner shall bring any action for partition, it being agreed that this restriction is necessary in order to preserve the rights of the Owners with respect to the operation and management of the Project. Judicial partition by sale of a single Unit owned by two or more persons and division of the sale proceeds is not prohibited hereby (but partition of title to a single Unit is prohibited). Notwithstanding the provisions of this Section 2.3, until all of the Units are conveyed by Declarant to a third party, Declarant has the right to:

2.3.1 physically combine the space within one Unit with the space within one or more adjoining Units, to redetermine the Common Interest of the Units so combined and to amend the Declaration and Map to include said changes;

002-47-2301

2.3.2 physically combine part of or a combination of parts of the space within one Unit with part or parts of space within one or more adjoining Units, to redetermine the Common Interest of the Units so combined and to amend the Declaration and Map to include said changes;

2.3.3 partition or subdivide any Unit owned by Declarant into two or more Units, Common Elements, or a combination of Units and Common Elements, to redetermine the Common Interest of those Units so partitioned or subdivided, and, if applicable, of all other Units, and to amend the Declaration and Map to include said changes; and

2.3.4 modify or remodel one or more Units into larger or smaller units or any combination thereof, to construct, alter, relocate or remove any walls or do any other work which may be necessary to complete such modification or remodeling, to redetermine the Common Interest of the Units altered, if any, and to amend the Declaration to include said changes.

2.4 General Reservations It is the intent of Declarant to develop the condominium regime established hereunder in several phases. "Phase I" shall be complete upon the filing of this Declaration and shall contain twenty-eight (28) Units and shall be situated on the land described as Exhibit E. The future phases contemplated by the Declarant as part of the condominium regime established hereunder may add additional Units of consistent workmanship, construction materials and design (now contemplated to be 252 Units) to the aforesaid condominium regime. Future phases shall be annexed, if at all, within seven (7) years from the filing of this Declaration and situated on the land described in Exhibits A and P. The Units located upon the real property to be annexed must be substantially completed prior to the annexation of such real property and the improvements thereon. Declarant shall not be obligated to develop any future phases. If future phases are added to the condominium regime by the Declarant, then the undivided percentage interest in the Common Elements appurtenant to each Unit (including Units previously developed in previous phases) shall be recalculated and redetermined according to the following formula, to wit:

- A = square footage of a Unit
- B = total square footage of all Units in all developed phases
- C = percentage of undivided interest in the Common Elements of all phases combined appurtenant to each Unit

$$\frac{A}{B} \times 100 = C$$

002-47-2302

Declarant hereby reserves the right at anytime hereafter to record an amendment to this Declaration or any other Project Documents to properly reflect the addition of the Units in the future phases, the portions of the land described in Exhibit A that constitute the additional Property subject to this Declaration and any other information necessary to effect the Declarant's aforesaid intent to expand the Ponderosa Forest Condominiums.

NOTICE IS HEREBY GIVEN TO ALL OWNERS THAT IN THE EVENT THAT DECLARANT DEVELOPS ONE OR MORE FUTURE PHASES AS SET FORTH ABOVE A UNIT SHALL HAVE A REDUCED PERCENTAGE OF UNDIVIDED INTEREST IN THE COMMON ELEMENTS.

This paragraph 2.4 shall control over any language in this Declaration or the other Project Documents that does or appears to contradict the language in the paragraph 2.4.

ARTICLE III.

ASSOCIATION, ADMINISTRATION,

MEMBERSHIP AND VOTING RIGHTS

3.1 Association to Manage Common Elements. The management of the Common Elements shall be vested in the Association in accordance with the terms of this Declaration and the Bylaws. A copy of the Bylaws which have been duly adopted by the Board of Directors of the Association is attached hereto as Exhibit "D" and incorporated herein by reference for all purposes; and all Owners of the Units and all holders of liens thereon shall be bound thereby. The Owners of all the Units covenant and agree that the administration of the Project shall be in accordance with the provisions of this Declaration, the Articles and the Bylaws, subject to the standards set forth in this Declaration and all applicable laws, regulations and ordinances of any governmental or quasi-governmental body or agency having jurisdiction over the Project or the Association, as same may be amended from time to time.

3.2 Membership. Any Person, upon becoming the Owner of a Unit, shall automatically be a Member of the Association, and shall remain a Member thereof in accordance with the Articles and the Bylaws until such time as his ownership of said Unit ceases for any reason, at which time his membership in the Association shall automatically cease, or be temporarily suspended as provided in Section 4.5.

3.3 Transferred Membership. Membership in the Association shall not be transferred, pledged or alienated in any way, except upon the transfer of ownership of the Unit to which it is appurtenant, and then only to the new Owner.

002-47-2303

3.4 Voting Rights The Owner (or Owners collectively) of each Unit shall be entitled to one vote. The value of such one vote shall equal the Common Interest assigned to the respective Unit as set forth in Exhibit C hereto. If more than one Person is the record holder of fee simple title of a Unit, then any one such Person may act, including vote, on behalf of all such Persons. In the event two or more Persons, who are record holders of fee simple title of a Unit, attempt to act or vote on behalf of a Unit; then the Board, in its sole discretion, shall determine and designate which Person shall so act or vote on behalf of such Unit.

3.5 Board of Directors The affairs of the Association shall be managed by a Board of Directors which has been established and which shall conduct regular and special meetings according to the provisions of the Bylaws.

3.6 Officers The officers of the Association shall be elected by the Board of Directors according to the provisions of the Bylaws.

3.7 Managing Agent The Board shall have the authority and duty to engage the services of a managing agent ("Managing Agent") (whose business expertise includes the professional management of condominiums) to maintain, repair, replace, administer, and operate the Property. The Management Agreement entered into between the Board and the Managing Agent shall be in writing and shall provide for payment to the Managing Agent of a management fee no higher than is usually paid to managers with similar qualifications, managing similar residential buildings (whether rental or condominiums) in the Houston-Galveston area of Texas. The said management fee shall be a Common Expense. Additionally, the said Management Agreement shall provide for termination by the Association without cause and without penalty, upon thirty (30) days written notice thereof, and shall provide for fidelity bonding of the Managing Agent, his employees or other persons or entities under his control who will or may handle the funds of the Association. The term of the Management Agreement shall not exceed one year, renewable by agreement of the parties for successive one-year periods.

3.8 Termination of Professional Management Notwithstanding any provision of this Declaration or any other establishing document to the contrary, Sections 3.7, 3.8 and 3.9 may not be amended, changed, modified, or rescinded and the Association may not terminate professional management and assume self management of the Property without prior written approval of fifty-one percent (51%) of the Institutional Lenders (based upon one vote for each Mortgage owned) and the written approval of the Owners of sixty-seven percent (67%) of the Common Elements.

002-47-2304

3.9 Initial Management Until control of the Association is vested in the purchaser of the Units (as provided for in Section 3.14 herein) and a new Board is elected and qualified, the Initial Board, as appointed in the Articles of Incorporation of the Ponderosa Forest Homeowners Association, Inc., shall exercise all of the powers, rights, duties and functions of the Board for the benefit of the Unit Owners. The Initial Board shall engage the services of a Managing Agent, which may or may not be affiliated with the Declarant, to manage the Property under an Initial Management Agreement expiring no more than one (1) year after the date control of the Association becomes vested in the Unit purchasers.

3.10 Non-liability of Board of Directors, Officers and Declarant; Board's Determination Binding Non-liability of the Board of Directors, Officers, and Declarant. Neither the Board nor officers of the Association nor Declarant shall be personally liable to the Unit Owners for any mistake of judgment or for any acts or omissions of any nature whatsoever as such directors, Board, officers, or Declarant, except for any acts or omissions found by a court to constitute gross negligence or fraud. The Owners shall indemnify and hold harmless each of the directors, Board, officers, or Declarant, and their respective heirs, executors, administrators, successors and assigns in accordance with the provisions of the Bylaws.

3.11 Board's Determination Binding In the event of any dispute or disagreement between any Owners relating to the Property, or any questions of interpretation or application of the provisions of the Declaration or Bylaws, such dispute or disagreement shall be submitted to the Board. The determination of such dispute or disagreement by the Board shall be binding on each and all such Owners, subject to the right of such Owners to seek other remedies provided by law after such determination by the Board.

3.12 Actions without Meetings Any action required by this Declaration or by the Bylaws to be taken at a meeting of the Association or at a meeting of the Board may be taken without a meeting if a consent in writing setting forth the action so taken, shall be signed by all of the Owners in the Association or the members of the Board, as the case may be, entitled to vote with respect to the subject matter thereof. Such consent shall have the same force and effect as a unanimous vote at such a meeting.

3.13 Notices Any notice permitted or required to be given to a member of the Board or to an Owner or Occupant may be delivered personally, by mail or by placing such notice in the mail distribution facilities of each Owner or Occupant if such facilities are present on the Property. If

002-47-2305

delivery is made by mail, it shall be deemed to have been delivered seventy-two (72) hours after deposit in the U.S. Mail, postage prepaid, addressed to an Owner or Occupant at the Unit or to such other address as the Owner may have given in writing to the Secretary of the Association for the purpose of service of notices. Any address for purposes of notice may be changed from time to time by notice in writing to the Secretary.

3.14 Control of the Association Paragraph 3.1 notwithstanding and for the benefit and protection of the Owners and any Institutional Lenders of record and for the sole purpose of insuring a complete and orderly buildout as well as a timely sellout of the Condominiums, including any annexations of future phases as provided in Paragraph 2.4, the Declarant's control of and over the Association shall not to exceed July 1, 1988; a date one hundred twenty (120) days from the sale of seventy-five percent (75%) of the Units, including any annexations, or when in the opinion of the Declarant the entire Project including all annexations becomes viable, self-supporting and operational, whichever occurs first. In no event shall Declarant's control extend beyond July 1, 1988, if all proposed phases are annexed and incorporated heretofore by merger. Within sixty (60) days after the date on which the Declarant's control of the Association ends, as specified herein, the Declarant, through the Board of Directors, shall call the first annual meeting of the Association.

ARTICLE IV.

MAINTENANCE AND ASSESSMENTS

4.1 Personal Obligation of Assessments Declarant, for each Unit owned within the Project, hereby covenants, and each Owner of any Unit by acceptance of a deed thereto, whether or not it shall be so expressed in such deed, is deemed, as a part of the purchase money consideration for such deed and conveyance, to covenant and agree to pay to the Association: (1) regular monthly Assessments or charges, and (2) special Assessments for capital improvements and unexpected expenses, such Assessments to be established and collected as provided herein, in the Bylaws and in the Rules and Regulations of the Association. No Owner of a Unit may exempt himself from liability for his contribution toward the Common Expenses by waiver of the use or enjoyment of any of the Common Elements or by the abandonment of his Unit.

4.2 Purposes of Assessments The Assessments levied by the Association shall be used exclusively to promote the recreation, health, safety and welfare of all the residents in the entire Project for the improvement and maintenance of the Common Elements for the common good of the Project. The

02-47-2306

Board may use said Assessments for said purposes, including, without limitation, providing for the enforcement of the provisions of this Declaration, the Bylaws and the Rules and Regulations promulgated thereunder. The decision of the Board with respect thereto shall be final so long as made in good faith. Annual Assessments shall include an adequate reserve fund for maintenance, repairs and replacement of the Common Elements. The Limited Common Elements shall be maintained as General Common Elements, and Owners having exclusive use thereof shall not be subject to any special charges for Assessments for the repair or maintenance thereof except as otherwise provided in the Bylaws and herein, including, but not limited to, Section 5.2. hereof.

4.3 Regular Monthly Assessments and Creation of Lien

All Owners shall be obligated to pay the Assessments imposed by the Board of Directors of the Association. The total amount of the estimated funds required from Assessments to operate the Project shall be set forth in a budget adopted by the Board of Directors and shall be assessed against each Owner in proportion to the Common Interest of such Owner as set forth herein, said figure to be divided by twelve (12) to determine the regular monthly Assessment; provided however that said Assessments based on said Common Interests may be rounded off to the nearest dollar figure and shall be secured by a lien against said Unit, subject to the provisions hereof. Declarant hereby reserves and assigns to the Association, without recourse, a vendor's lien against each Unit to secure the payment of any regular or special Assessment which may be levied pursuant to the terms hereof, and the expenses incurred in connection with the enforcement thereof, including, without limitation, interest at the rate provided in Section 4.5, costs and reasonable attorney's fees. Said liens may be enforced by appropriate judicial proceedings, and the amounts secured thereby shall be the obligation of and chargeable to the Owner in default. Any such lien shall be and is subordinate and inferior only to the following: (i) assessments, liens and charges in favor of the State of Texas and any political subdivision thereof for taxes past due and unpaid on such Unit; and (ii) amounts due under any first lien Mortgage instruments duly recorded prior to the recordation of any lien assessment as provided in Section 4.5.

4.4 Special Assessments

In addition to the regular monthly Assessments authorized above, the Board may levy, in any year, one or more Special Assessments applicable to that year only for the purpose of defraying, in whole or in part, the cost of any construction, reconstruction, repair or replacement of any capital improvements upon the Common Elements, including fixtures and personal property related thereto, or to defray any unanticipated or underestimated expense or other action or undertaking normally covered by a

002-47-2307

regular Assessment (and, where necessary, for taxes assessed against the Common Elements or the Project as a whole). Said special Assessments shall be assessed against each Owner in proportion to the Common Interest of such Owner as set forth herein. Special Assessments may also be levied against an individual Unit and its Owner to reimburse the Association for costs incurred in bringing that Owner and his Unit into compliance with the provisions of this Declaration and the Bylaws including actual attorney's fees and costs. Said special Assessments may be subject to such limitations as are provided in the Bylaws.

4.5 Assessment Lien All sums assessed but unpaid for the share of Assessments chargeable to any Unit, including interest thereon at the maximum rate permitted by law per annum from the date such Assessments are due until said Assessments are paid, subject to the provisions hereof limiting the interest contracted for, charged or received to the maximum permitted by applicable law, shall constitute a lien on such Unit superior to all other liens and encumbrances, except as provided in Section 4.3. The Board of Directors or a managing agent appointed by the Board ("Managing Agent") may (but shall not be required to) prepare a written notice setting forth the amount of such unpaid indebtedness, the name of the Owner of the Unit and a description of the Unit. Such notice shall be signed by one of the members of the Board of Directors or by one of the officers of the Association or by a representative of the Managing Agent and may be recorded in the Office of the County Clerk of Galveston County, Texas. Such lien may be enforced by the foreclosure of the defaulting Owner's Unit by the Association in like manner as a mortgage on real property subsequent to the recording of a notice provided for above. In any such proceeding, the Owner shall be required to pay the costs, expenses and attorney's fees incurred in connection with filing the lien, and in the event of any foreclosure proceeding, all additional costs, expenses and attorney's fee incurred in connection with any such foreclosure proceeding. The Owner of the Unit being foreclosed shall be required to pay to the Association the monthly Assessment for the Unit during the period of foreclosure, and the Association shall be entitled to the appointment of a receiver to collect the same. The Association shall have the power to bid on the Unit at foreclosure or other legal sale and to acquire and hold, lease, mortgage, vote the votes appurtenant to, convey or otherwise deal with the same. Any Mortgagee holding a lien on a Unit may pay, but shall not be required to pay, any unpaid Assessments owing with respect to such Unit, but such payment shall not be deemed a waiver of the Owner's default by either the Association or such Mortgagee.

02-47-2308

The amount of the Common Expenses assessed on each Unit shall also be a debt of the Owner thereof at the time the Assessment is made. Suit to recover a money judgment for unpaid Common Expenses shall be maintainable without foreclosing or waiving the lien securing same.

Each Owner, by acceptance of a deed to a Unit, hereby expressly vests in the Association or its agents the right and power to bring all actions against such Owner personally for the collection of such charges as a debt, and to enforce the aforesaid liens by all methods available for the enforcement of such liens, including non-judicial foreclosure pursuant to Article 3810 of the Texas Revised Civil Statutes, and such Owner hereby expressly grants to the Association the private power of sale in connection with said liens and in the event of such a sale such Owners, their heirs and assigns, shall continue to possess such Unit as tenants at will of such purchaser, and the purchaser shall be entitled to institute and maintain an action for forcible detainer of said property in the Justice of the Peace Court in the Justice Precinct in which such property, or any part thereof, is situated.

The Association may also temporarily suspend the Association membership rights of any Owner who is in default in payment of any Assessment in accordance with the Bylaws. Such temporary suspension shall not effect any Owner's obligation for past or future Assessments or the Association rights or remedies in collecting such Assessments. The Association may also temporarily suspend in accordance with the Bylaws the rights of an Owner who is in default in payment of any Assessment to use the Condominiums' recreational facilities. The Association may also have temporarily disconnected any and all utility service (s) supplied to a Unit whose Owner is in default in payment of any Assessment if such utility service is paid for by the Association directly to such utility as a Common Expense.

4.6 Date of Commencement of Assessment; Due dates The regular monthly Assessments provided for herein shall commence as to all Units in the Project on the first day of the month following the conveyance by deed of the first Unit in the Project. Thereafter, due dates of regular monthly Assessments shall be the first day of each and every subsequent calendar month. No notice of such Assessments or the due dates thereof shall be required other than an annual notice setting forth the amount of the regular monthly Assessments. The due date of any special Assessment shall be the due date specified by the Association in the notice of such special Assessment delivered by the Association to each Owner; provided, however, such due date shall in no event be less than thirty (30) days subsequent to the date of such notice.

002-47-2309

4.7 Transfer of Unit by Sale or Foreclosure Sale or transfer of any Unit shall not affect the Assessment lien. However, the sale or transfer of any Unit pursuant to foreclosure of a Mortgage, or by deed or other transfer in lieu thereof, shall extinguish the lien of such Assessments as to payments which become due prior to such sale or transfer (except for Assessments which became due prior to the recordation of such Mortgage). No such sale or transfer shall relieve such Unit from liability for any Assessments thereafter becoming due or from the lien thereof. When any Mortgagee of a Mortgage obtains title to a Unit as a result of foreclosure of such Mortgage, or by deed or other conveyance in lieu thereof, such Mortgagee shall not be liable for the unpaid dues or charges of the Association chargeable to such Unit which accrued subsequent to the recordation of such Mortgage and prior to the acquisition of title to such Unit by such Mortgagee. Such unpaid dues or charges shall be deemed to be Common Expenses collectible from all of the Units including the Unit acquired by such Mortgagee. In a voluntary conveyance of a Unit (other than a deed or conveyance to a Mortgagee in lieu of foreclosure), the grantee of the same shall be jointly and severally liable with the grantor for all unpaid Assessments by the Association against the latter for his share of the Common Expenses up to the time of the grant or conveyance, without prejudice to the grantee's right to recover from the grantor the amounts paid by the grantee therefor. However, any such grantee or prospective grantee, upon payment to the Association of a reasonable fee not to exceed Twenty-Five and no/100 Dollars (\$25.00) and upon written request, shall be entitled to a statement from the Association, setting forth the amount of any unpaid Assessments then due and owing to the Association with respect to the Unit being purchased, and such grantee shall not be liable for, nor shall the Unit conveyed be subject to a lien for, any unpaid Assessments made by the Association against the Unit and/or its Owner (s) in excess of the amount set forth in the statement and applicable to a period of time prior to the date of such statement; provided, however, the grantee shall be liable for any such Assessments becoming due after the date of any such statement.

4.8 Separate Taxation Each Unit, together with its Common Interest, shall be deemed to be a separate and distinct entity for the purpose of the assessment and collection of taxes, assessments and other charges of this state, or of any political subdivision, special improvement district or any other taxing or assessing authority. The lien for taxes assessed to any Unit shall be confined to that Unit. No forfeiture or sale of any Unit shall divest

W2-47-2310

or in any way affect title to any other Unit. In the event that such taxes or assessments for any year are not separately assessed to each Unit but rather are assessed on the Project as a whole, then each Owner shall pay his proportionate share thereof in accordance with his Common Interest and, in said event, such taxes or assessments shall be a Common Expense. If necessary, a special Assessment or Assessments may be levied against the Units in an amount equal to said taxes, to be paid thirty (30) days prior to the due date thereof.

4.9 Working Capital Fund Within sixty (60) days following the closing of the sale of the first Unit in the Condominium Project there will be established an initial working capital fund for the use and benefit of the Association in paying unforeseen expenditures and/or to purchase any additional equipment or services. The aforesaid fund shall equal two (2) months' estimated regular monthly Assessments for each Unit, but this sum will not be considered advance payment of any regular monthly Assessments.

ARTICLE V.

DUTIES AND POWERS OF THE ASSOCIATION

5.1 Duties and Powers In addition to the duties and powers enumerated in the Bylaws and the Articles, or elsewhere provided for herein, and without limiting the generality thereof, the Association shall:

5.1.1 Maintain, repair, replace, restore, operate and manage all of the Common Elements and all facilities, improvements, furnishings, equipment and landscaping thereon, and all property that may be acquired by the Association in good condition. This obligation shall not extend to any portion or facility of the Common Elements required to be maintained by an individual Owner under this Declaration (specifically including, but not limited to, Sections 5.2, 5.3 and 9.7) or the Bylaws.

5.1.2 Enforce the provisions of this Declaration by appropriate means, including, without limitation, the expenditures of funds of the Association, the employment of legal counsel and the commencement and prosecution of actions.

002-47-2311

5.1.3 Maintain such policy or policies of insurance as are required by this Declaration or as the Board deems necessary or desirable in furthering the purpose of, and protecting the interests of, the Association and its Members.

5.1.4 Grant and reserve easements where necessary or desirable for utilities and utility facilities over the Common Elements and Units to serve the Common Elements and the Units and amend the Map to show same.

5.1.5 Have the authority to employ a manager or other persons and to contract with independent contractors or Managing Agents to perform all or any part of the duties and responsibilities of the Association, subject to the Bylaws and restrictions imposed by any governmental or quasi-governmental body or agency having jurisdiction over or interest in the Project, specifically including, but not limited to, the Federal Home Loan Mortgage Corporation and the Federal National Mortgage Association. Notwithstanding anything to the contrary contained herein or in the Bylaws, the Association shall not terminate professional management of the Project and assume self management thereof without the written approval detailed in Section 3.8.

5.1.6 Keep or cause to be kept records with detailed accounts of the income, receipts and expenditures affecting the Project and its administration, specifying the maintenance and repair expenses with regard to the Common Elements and any other expenses incurred by or on behalf of the Project or Association. The records so kept shall be available for inspection by all Owners and Mortgagees of Units during regular business hours of the Association that shall be set and announced for general knowledge. All records shall be kept in accordance with generally accepted accounting principles and shall be audited at least once a year by an independent auditor. Copies of the auditor's reports shall be made available to all Owners and Mortgagees upon written request and free of charge.

5.1.7 Adopt reasonable rules not inconsistent with this Declaration, the Articles, or the Bylaws relating to the use of the Common Elements and all facilities thereon, and the conduct of Owners and their tenants and guests with respect to the Project and other Owners.

002-47-2312

5.2 Maintenance of Project by Association The Association shall provide maintenance of the Project as provided in the bylaws. The responsibility of the Association for maintenance and repair shall not extend to the cost and expense of repairs or replacements arising out of or caused by the willful or negligent act or neglect of any Owner, or his guests, tenants or invitees. The cost and expense of repair or replacement of a Unit exterior or of any portion of the Common Elements resulting from such excluded items shall be the responsibility of such Owner who (or whose guests, tenants or invitees) neglects or willfully damages such excluded items. The Association may cause such repairs and replacements to be made at such Owner's sole cost and expense, and if said Owner shall fail to pay for such repairs or replacements upon demand, the cost thereof (plus interest from the date of payment(s) at the maximum legal rate) shall be added to the Assessments chargeable to such Unit and shall be payable to the Association by the Owner of such Unit upon demand.

5.3 Association Easements and Access to Units For the purpose of performing the maintenance, repair or replacement authorized by this Article or for any other purpose reasonably related to the performance by the Board of its responsibilities under this Declaration, the Association (and its agents and employees) shall have a non-exclusive easement over and onto all portions of the Common Elements, and shall also have the right, after reasonable notice to the Owner, and at reasonable hours, to enter any Unit for such purposes and to enter any Unit without notice at any time in the event of an emergency. Should any Owner change any lock on any entrance to his Unit, such Owner shall immediately provide to the Board a key to the new lock. Damage to the interior or any part of a Unit or Units resulting from the maintenance, repair, emergency repair or replacement of any of the Common Elements or as a result of emergency repairs within another Unit at the instance of the Association shall be a Common Expense of all the Owners; provided, however, that if such damage is the result of the neglect, misuse or negligence of an Owner, then such Owner shall be responsible and liable for all such damage. All damaged improvements shall be restored to substantially the same condition of such improvements prior to damage. All maintenance, repairs and replacements as to the General Common Elements, whether located under or outside of Units (unless required to be maintained by an individual Owner under this Declaration or necessitated by the neglect, negligence, or misuse by an Owner or his guests, tenants or invitees, in which case such expense shall be charged to such Owner) shall be the Common Expenses of all the Owners.

ARTICLE VI.

UTILITIES

6.1 Owners' Rights and Duties The rights and duties of the Owners of Units within the Project with respect to utilities shall be as follows:

002-47-2313

6.1.1 Each Owner shall pay for his own utilities which are separately metered and billed to each Unit by the respective utility companies or submetered and billed to each Unit by the Association. Any such utility expenses billed to each Unit by the Association shall be deemed to be special Assessments hereunder and shall be secured by the lien reserved in Section 4.3. Utility expenses which are not metered or submetered and separately billed shall be part of the Common Expenses, and each Owner shall pay his pro-rata share thereof as in the case of other Common Expenses.

6.1.2 Whenever sanitary sewer, water, electric, gas, television receiving (including cable television), or telephone lines or connections, heating or air conditioning conduits, ducts, or flues (such items being hereinafter collectively called the "connections") are located or installed within the Project, which connections, or any portion thereof, lie in or upon more than one Unit, Declarant reserves for the use and benefit of the Association the right and an easement to the full extent reasonably necessary therefor, to enter upon the Units or to have the public, private or municipal utility companies enter upon the Units in or upon which said connections, or any portion thereof lie, to repair, replace and generally maintain said connections as and when reasonably necessary; provided, however, the exercise of such easement rights shall be in a manner reasonably calculated to cause as minimal interference with the continued use and occupancy of the Units so affected by the Owners thereof, while still adequately serving the purposes for which they are granted.

6.1.3 Whenever connections are located or installed within the Project, which connections serve more than one Unit, the Owner of each Unit served by said connections shall be entitled to the full use and enjoyment of such portions of said connections as service his Unit.

6.2 Easement for Utilities and Maintenance Easements over and under the Property for the installation, repair, and maintenance of sanitary sewer, water, electric, gas, and telephone lines and facilities, heating and air-conditioning facilities, cable or master television antenna lines, drainage facilities, walkways, and landscaping as are shown on the Map, and as may be hereafter required to serve the Property are hereby reserved by Declarant for the use and benefit of the Association, together with the right to grant and transfer the same.

6.3 Association's Duties The Association shall maintain all utility installations located in the Common Elements except for those installations maintained by utility companies, public, private or municipal. The Association shall pay all charges for utilities supplied to the Project except those metered or submetered and charged separately to the Units.

002-47-2314

ARTICLE VII.

USE RESTRICTIONS

In addition to all of the covenants contained herein, the use of the Project and each Unit therein is subject to the following:

7.1 Use of Individual Units No Unit shall be occupied and used except for residential purposes by the Owner, their tenants, and social guests, and no trade or business shall be conducted therein; provided, however, that Declarant may use any Unit or Units in the Project owned by Declarant for a model home site or sites and display and sales office until the last Unit in the entire Project is sold. No more than four(4) individuals may occupy a three (3) bedroom Unit; no more than three (3) individuals may occupy a two (2) bedroom Unit; and no more than two (2) individuals may occupy a one (1) bedroom Unit; provided, however, that in determining the number of bedrooms in a Unit, a den shall be counted as a bedroom.

7.2 Nuisances No noxious, illegal, or offensive activities shall be carried on in any Unit or in any part of the Project, nor shall anything be done thereon which may be or may become an annoyance or a nuisance to, or which may in any way interfere with, the quiet enjoyment of each of the Owners of his respective Unit, or which shall in any way increase the rate of insurance for the Project, or cause any insurance policy to be cancelled or cause a refusal to renew the same, or which will impair the structural integrity of any Building.

7.3 Vehicle Restrictions No trailer, camper, mobilehome, Recreational Vehicle, commercial vehicle, truck (other than standard size pickup truck), inoperable automobile, boat or similar equipment shall be permitted to remain upon any area within the Project, other than temporarily (for purposes of loading and unloading of passengers or personal property), unless in an area specifically designated for such purpose by the Board. Commercial vehicles shall not include sedans or standard size pickup trucks which are used both for business and personal use, provided that any signs or markings of a commercial nature on such vehicles shall be unobtrusive and inoffensive as determined by the Board. No noisy or smoky vehicles shall be operated on the Project. No off-road unlicensed motor vehicles shall be maintained or operated upon the Project, except as may be reasonably necessary to the execution of the rights or duties of the Association under this Declaration.

7.4 Signs Declarant may place signs in or around the Common Elements and use the Common Elements for sales purposes until the last Unit in the entire Project is sold.

02-47-2315

Owners other than Declarant, however, are prohibited from placing "for sale," "for rent" or any other sign in or around the Common Elements or displaying signs to the public view on any Unit or any portion of the Project.

7.5 Animals No animals or birds of any kind shall be raised, bred, or kept in any Unit, or on any portion of the Project except as permitted in the Bylaws or in the rules and regulations adopted by the Board and published from time to time.

7.6 Garbage and Refuse Disposal All rubbish, trash and garbage shall be regularly removed from the Project and shall not be allowed to accumulate thereon. Trash, garbage and other waste shall not be kept except in sanitary containers in accordance with the Bylaws and the rules and regulations adopted by the Board and published from time to time. All equipment, garbage cans, woodpiles, or storage piles shall be kept screened and concealed from view of other Units, streets, and the Common Elements.

7.7 Radio and Television Antennas No alteration to or modification of a central radio or television antenna system or cable television system, whichever is applicable, shall be permitted, and no Owner shall be permitted to construct, use, or operate his own external radio, television antenna, or other electronic antenna without the prior written consent of the Board. No Citizens Band transmitter or other transmission device shall be permitted on the Project without the prior written consent of the Board.

7.8 Right to Lease The respective Units shall not be rented by the Owners thereof for transient or hotel purposes, which shall be defined as rental for any period less than thirty (30) days, nor shall less than an entire Unit be rented or leased. Subject to the foregoing restrictions and to those of Section 7.9 hereof, the Owners of the respective Units shall have the absolute right to lease the Units provided that the lease is in writing and is made subject to the covenants, conditions, easements, restrictions, limitations, liens for Common Expenses and uses contained in this Declaration and the Bylaws, and any rules and regulations adopted by the Board and published from time to time. Notwithstanding any of the foregoing, the right of Declarant to rent or lease Units until their initial transfer to any third party or parties is hereby specifically reserved.

7.9 Mortgaging a Unit-Priority Any Owner shall have the right from time to time to mortgage or encumber his interest by deed of trust, mortgage or other security instrument. A first mortgage shall be one which has first and paramount priority under applicable law.

02-47-2316

An Owner may create and grant a second lien mortgage or deed of trust against his Unit on the following conditions: (1) That any such second lien mortgage or deed of trust shall always be subordinate to all of the terms, conditions, covenants, restrictions, uses, limitations, easements, obligations and liens for Common Expenses and other payments created by this Declaration and by the Bylaws; and (2) That the mortgagee under any second lien mortgage or deed of trust shall release by written recordable instrument, for the purpose of restoration of any improvements upon the mortgaged premises, all of his right, title and interest in and to the proceeds under all insurance policies upon said premises, which insurance policies were effected and placed upon the mortgaged premises by the Association. Such release shall be furnished to the Association by the mortgagee under any second lien mortgage or deed of trust promptly following written request therefor by the Association.

7.10 Power Equipment and Car Maintenance No power equipment, work shops, or car maintenance of any nature whatsoever shall be permitted on the Project except with prior written approval of the Board. In deciding whether to grant approval, the Board shall consider the effects of noise, air pollution, dirt or grease, fire hazards, interference with radio or television reception, and similar objections.

7.11 Liability of Owners for Damage to Common Elements The Owner of each Unit shall be liable to the Association for all damages to the Common Elements or improvements thereon caused by the neglect, misuse or negligence of such Owner or any tenant or other occupant of his Unit, guest or invitee.

7.12 No Warranty of Enforceability While Declarant has no reason to believe that any of the restrictive covenants or other terms and provisions contained in this Article VII or elsewhere in this Declaration are or may be invalid or unenforceable for any reason or to any extent, Declarant makes no warranty or representation as to the present or future validity or enforceability of any such restrictive covenants, terms or provisions. Any Owner acquiring a Unit in the Project in reliance on one or more such restrictive covenants, terms or provisions shall assume all risks of the validity and enforceability thereof and, by acquiring the Unit agrees to hold Declarant harmless therefrom.

ARTICLE VIII.

ARCHITECTURAL CONTROL

8.1 Prohibition of Alteration and Improvement Subject to the exemption of Declarant under Section 9.10 below, no building, fence, wall, obstruction, balcony, screen, patio

002-47-2317

patio cover, tent, awning, carport, carport cover, improvement, or structure of any kind shall be demolished, erected, painted or maintained upon the Project, nor shall alteration or improvement of any kind be made thereto (save and except for repainting and redecorating of the interior of a Unit by an Owner) until the same has been approved in writing by the Board or by an Architectural Control Committee (the "Committee") appointed by the Board and/or Declarant as provided in this Article.

8.2 Plans and Approval Plans and specifications showing the nature, kind, shape, color, size, materials and location of such improvements or alterations, shall be submitted to the Board or Committee for approval as to such matters as quality of workmanship and design and harmony of structural and external design with existing structures, and as to location in relation to surrounding structures, topography, and finish grade elevation. No permission or approval shall be required to rebuild in accordance with Declarant's original plans and specifications, or to rebuild in accordance with plans and specifications previously approved by the Board or Committee. No landscaping of patios or yards visible from the street, from other Units or from the Common Elements shall be undertaken by any Owner until plans and specifications showing the nature, kind, shape, design and location of the proposed materials shall have first been submitted to and approved in writing by the Board or Committee. The Board or Committee shall respond in writing within sixty (60) days from the date it receives said requests for approval of plans and specifications required under this Section 8.2. If the Board or Committee does not respond in writing within said sixty (60) day period, the Board or Committee shall be deemed to have approved said request.

8.3 Architectural Control Committee The number, appointment and term of members of the Committee shall be as provided in the Bylaws, subject to the following limitations:

8.3.1 If a Committee is appointed, there shall be not less than three (3) nor more than five (5) members of the Committee.

8.3.2 Declarant may appoint all of the original members of the Committee and all replacements until the last Unit in the entire Project is sold. Thereafter, the Board shall have the power to appoint all of the members of the Committee. Committee members appointed by the Declarant need not be members of the Association. Committee members appointed by the Board shall, however, be from the membership of the Association.

002-47-2318

ARTICLE IX.

GENERAL PROVISIONS

9.1 Enforcement The Association, any Owner, and any governmental or quasi-governmental agency or municipality having jurisdiction over the Project shall have the right to enforce, by any proceeding at law or in equity, all restrictions, conditions, covenants, reservations, easements, liens, and charges now or hereafter imposed by this Declaration, and in such action shall be entitled to recover costs and reasonable attorneys' fees as are ordered by the Court; provided, however, that an individual Owner shall have no right to enforce the collection of any Assessment levied against any other Owner under Article IV above. Failure by any such Person to enforce any such provision shall in no event be deemed a waiver of the right to do so thereafter.

9.2 Invalidity of Any Provision Should any provision of this Declaration be declared invalid or in conflict with any law of the jurisdiction where the Project is situated, the validity of all other provisions shall remain unaffected and in full force and effect.

9.3 Encroachment and Protrusion Easements Each Unit within the Project is hereby declared to have an easement over all adjoining Units and the Common Elements for the purpose of accommodating any encroachment and/or protrusion due to engineering errors, errors in original construction, settlement or shifting of any Building, or any other cause. There shall be valid easements for the maintenance of said encroachment and/or protrusions as long as they shall exist, and the rights and obligations of Owners shall not be altered in any way by said encroachments, protrusions, settlement or shifting; however, that in no event shall a valid easement for encroachment or protrusion be created in favor of an Owner or Owners if said encroachment or protrusion occurred due to the willful misconduct of said Owner or Owners. In the event a structure is partially or totally destroyed, and then repaired or rebuilt, the Owners of each Unit agree that minor encroachments and/or protrusions over adjoining Units or Common Elements shall be permitted and that there shall be a valid easement for the maintenance of said encroachments and/or protrusions so long as they shall exist. Such encroachments or protrusions shall not be considered to be encumbrances either on the Common Elements or on a Unit for purposes of marketability of title or otherwise.

9.4 Termination of Mechanic's Lien Rights and Indemnification No labor performed or materials furnished and incorporated in a Unit with the consent or at the request of an Owner or his agent, contractor or sub-

002-47-2319

contractor shall be the basis for the filing of a lien against either the Common Elements or the Unit of any other Owner not expressly consenting to or requesting the same, except that express consent shall be deemed to be given by the Owner of any Unit to the Board or Managing Agent in the case of emergency repairs. Each Owner shall indemnify and hold harmless each of the other Owners from and against any and all liability arising from any such claims or liens against the Units of any other Owners or against the Common Elements for construction performed or for labor, materials, services or other products incorporated in the indemnifying Owner's Unit at such indemnifying Owner's request. Labor performed or materials furnished for the General Common Elements, if duly authorized by the Managing Agent or the Board in accordance with the Declaration or Bylaws, shall be deemed to be performed or furnished with the express consent of each Owner and shall be the basis for the filing of a lien pursuant to law against each Unit in the Project.

9.5 Mortgage Protection Clauses

9.5.1 Right of Mortgagees No breach of any of the covenants, conditions and restrictions contained in this Declaration, nor the enforcement of any lien provisions herein, shall render invalid the lien of any first lien Mortgage (meaning a Mortgage with first priority over any other mortgage) on any Unit made in good faith and for value, but all of said covenants, conditions and restrictions shall be binding upon and effective against any Owner whose title is derived through foreclosure or trustee's sale, or otherwise, unless otherwise provided herein.

9.5.2 Notice to Lenders All Institutional Lenders that have filed with the Association an appropriate written request, shall be entitled to receive the following notices in writing from the Association:

9.5.2.1 Notice of any proposed change in the Project Documents, which notice shall be given thirty (30) days prior to the effective date of such change;

9.5.2.2 Notice of default by the Owner or grantor of any Mortgage on a Unit (the beneficial interest in which is held by said Institutional Lender) in the performance of such Owner's or grantor's obligations under the Project Documents, which default is not cured within thirty (30) days.

002-47-2320

9.5.2.1 Notice of any damage or destruction to any individual Unit or object to a Mortgage (the beneficial interest in which is held by said Institutional Lender), which damage exceeds One Thousand Dollars (\$1,000.00), which notice shall be given immediately upon the Board's obtaining knowledge of such damage or destruction; and

9.5.2.4 Notice of any loss to or taking of any portion of the Common Elements or facilities or improvements thereon, which loss or taking exceeds Ten Thousand Dollars (\$10,000.00) which notice shall be given immediately upon the Board's obtaining knowledge of such loss or taking.

9.5.3 Changes Requiring Lender Approval Without the prior written approval of at least sixty-seven percent (67%) of the Institutional Lenders (based upon one (1) vote for each Mortgage owned) and sixty-seven percent (67%) of the undivided interest in the Common Elements held by the Owners other than Declarant (except to the extent a higher percentage of approval may be expressly required elsewhere herein or by applicable law), the Association shall not be entitled to:

9.5.3.1 By act or omission, seek to abandon or terminate the Condominium Project, except for abandonment or termination of the Project provided by law, in case of substantial destruction by fire or other casualty or in the case of a taking by condemnation or eminent domain;

9.5.3.2 Change the pro rata interest or obligations of any Unit for the purpose of (i) levying assessments or charges or allocating distributions of hazard insurance proceeds or condemnation awards, or (ii) determining the pro rata share of ownership of each Unit in the Common Elements; provided, however, that nothing herein shall prevent Declarant from redetermining and reallocating between Units owned by Declarant the pro rata share of ownership in the Common Elements of such Units owned by Declarant which Declarant combines, partitions or subdivides prior to sale of such Units to a third party;

9.5.3.3 Partition or subdivide any Unit, except as provided in Section 2.3, provided that nothing contained herein or in Section 2.3 shall prevent Declarant from combining, partitioning or subdividing Units owned by Declarant;

002-47-2321

9.5.3.4 By act or omission, seek to abandon, partition, subdivide, encumber, sell or transfer the Common Elements (the granting of easements for public utilities or for other public purposes consistent with the intended use of the Common Elements by the Project shall not be deemed a transfer within the meaning of this clause);

9.5.3.5 Use Hazard insurance proceeds for losses to any property on the Project (whether to Units or to Common Elements) for other than the repair, replacement or reconstruction thereof, except as provided by applicable statute in case of substantial loss or damage to the Units and/or the Common Elements.;

9.5.3.6 Add to or amend any material provisions of the Project Documents, including those provisions which establish, provide for, govern or regulate voting; assessments, assessment liens or subordination of such liens; reserves for maintenance, repair and replacement of the Common Elements; insurance or fidelity bonds; rights to use the Common Elements; responsibility for maintenance and repair of the several portions of the Project; or withdrawal of property to or from the Project; boundaries of any Unit; convertability of Units into Common Elements or Common Elements into Units; leasing of Units; imposition of any right of first refusal or similar restriction on the right of any Owner to sell, transfer or otherwise convey his or her Unit; and any provisions which are for the express benefit of any Institutional Lender or guarantor of first lien mortgages on Units. (An addition or amendment to the Project Documents shall not be considered material if it is for the purposes of correcting technical errors, or for clarification only.);

9.5.3.7 Establish self-management when professional management has been previously required);

9.5.3.8 Restore or repair the Project in a manner other than specified in the documents; or

9.5.3.9 Take any action to terminate the status of the Project after substantial destruction or condemnation.

012-47-2322

An Institutional Lender who receives a written request to approve additions or amendments and who does not deliver or mail to the requesting party a negative within thirty (30) days shall be deemed to have given written approval of such request.

9.5.4 Mortgage Priority Notwithstanding any language contained in this Declaration or the other Project Documents to the contrary, no Owner or other party shall have priority over any rights of the Mortgagee of any Unit pursuant to its Mortgage in the case of a distribution to the Owner of such Unit of insurance proceeds or condemnation awards for losses to or taking of all or a portion of such Unit and/or Common Elements. Institutional Lenders shall have the right to examine the books and records of the Association at all reasonable times during regular business hours of the Association.

9.5.5 Compliance with FHLMC and FNMA Regulations The Declarant intends that the Project shall comply with all requirements of the Veterans Administration ("VA") and the Federal Housing Administration ("FHA") the Federal Home Loan Mortgage Corporation ("FHLMC") and the Federal National Mortgage Association ("FNMA") pertaining to the purchase or guarantee by VA, FHA, FHLMC and/or FNMA of home loans. Declarant and all Owners therefore agree that, notwithstanding anything to the contrary contained herein, in the event the Project or any of the Project Documents do not comply with the VA, FHA, FHLMC and/or FNMA requirements, the Declarant and/or the Board shall have the power (on behalf of the Association and each and every Owner) to amend the terms of this Declaration and the Bylaws and/or to enter into any agreement with VA, FHA, FHLMC and/or FNMA (or their designees) or the Mortgagees of the Units reasonably required by VA, FHA, FHLMC and/or FNMA or the Mortgagees to allow the Project to comply with such requirements.

9.5.6 Taxes, Assessments, and Charges Which May Become Liens All taxes, assessments, and charges which may become liens prior to any first lien Mortgage under local law shall relate only to the individual Units and not to the Project as a whole.

9.6 Revocation or Amendment to Declaration This Declaration shall not be revoked unless all of the Owners and all of the holders of any recorded first lien Mortgage covering or affecting any or all of the Units unanimously consent and agree to such revocation by instrument(s) duly recorded. Except as set forth in Section 9.5.5, this Declaration shall not be amended unless the Owners representing an aggregate ownership interest of at least fifty-one percent (51%), of the Common Elements and all of

002-47-2323

the holders of any recorded first lien mortgage covering or affecting any or all Units consent and execute each amendment by instrument(s) duly recorded; provided, however, that the percentage of the undivided interest in the Common Elements appurtenant to each Unit, as expressed in this Declaration, shall have a permanent character and shall not be altered without the consent of all of the Owners expressed in an amended Declaration duly recorded (subject only to the rights of Declarant to unilaterally change such percentage of undivided interest as set forth in Sections 2.3 and 9.5.3.2), and provided, further that revocation of this Declaration shall always require the consent of all of the Owners. Notwithstanding the foregoing, before the first annual meeting of the Association, Declarant may, without the written consent of any Institutional Lender of any Unit which would be affected (and without the consent of any Owner amend this Declaration, Map, Bylaws, any other Exhibits attached hereto or any of the Project Documents which amendments may include by way of example, but not be limited to those made pursuant to Sections 1.15, 1.16, 2.3 and 2.4.

9.7. Owner's Right and Obligation to Maintain and Repair Except for those portions of the Project which the Association is required to maintain and repair as provided herein and in the Bylaws, each Unit Owner shall, at his sole cost and expense, maintain and repair his Unit and any Limited Common Elements appurtenant to his Unit, keeping the same in good condition. Additionally, each Owner shall, at his sole cost and expense, maintain, repair and replace as necessary any separate air conditioning and heating units which serve only his Unit. Each Owner shall have the exclusive right to paint, plaster, panel, tile, wax, paper or otherwise refinish and decorate the inner surfaces of the walls, ceilings, floors, windows and doors bounding his Unit. In the event an Owner fails to maintain his Unit as provided herein in a manner which the Board deems necessary to preserve the appearance and value of the Project, the Board may notify such Owner of the work required and request that it be done within sixty (60) days from the giving of such notice. In the event such Owner fails to complete such maintenance within said period, the Board may cause such work to be done and may specially assess the cost thereof to such Owner and, if unpaid, create a lien against his Unit for the amount thereof as in section 4.3.

9.8 Insurance; Damage or Destruction

9.8.1 Association Liability Insurance The Association shall obtain and continue in effect comprehensive public liability insurance insuring the Association, the Declarant and the agents and employees of each and the Owners and the respective family members, guests, and invitees of the Owners against any liability

002-47-2324

incident to the ownership or use of the following elements, commercial spaces, if any, and public ways, and including, if obtainable, a cross-liability endorsement insuring each insured against liability to each other insured, and a "severability of interest" endorsement precluding the insurer from denying coverage to one Owner because of the negligence of other Owners or the Association. The scope of the coverage must include all other coverage in the kinds and amounts commonly required by private institutional mortgage investors for projects similar in construction, location, and use. Coverage shall be in an amount not less than One Million Dollars (\$1,000,000.00) per occurrence, for personal injury and/or property damage.

9.8.2 Master Hazard Insurance Additionally, the Association shall obtain and continue in effect a master or blanket policy of multi-peril insurance on the Project, providing as a minimum fire and extended coverage and all other coverage in the kinds and amounts commonly required by private institutional mortgage investors for projects similar in construction, location and use on a replacement cost basis in an amount not less than one hundred percent (100%) of the insurable value (based upon replacement cost) of all improvements on the Project. If there is a steam boiler in operation in connection with any Unit, there must be in force boiler explosion insurance evidenced by the standard form of boiler and machinery insurance policy and providing minimum coverage in an amount not less than Fifty Thousand Dollars (\$50,000.00) per accident per location. If the Project is located in an area identified by the Federal Emergency Management Agency as an area having special flood hazards, a "blanket" policy of flood insurance on the Project must be maintained in the amount of the aggregate of the outstanding principal balances of the mortgage loans on all Units in the Project or the maximum limit of coverage available under the National Flood Insurance Act of 1968, as amended, whichever is less. The master Policy of multi-peril insurance shall contain extended coverage and replacement costs endorsements, if available, and may also contain vandalism and malicious mischief coverage, special form endorsement, stipulated amount clause and a determinable cash adjustment clause, or a similar clause to permit cash settlement covering full value of the improvements on the Project in the event of destruction and a decision not to rebuild pursuant to this Declaration. Such policies shall be in form and amount as may be determined by the Board (provided that such policies must be acceptable to the Federal Home Loan Mortgage Corporation and the Federal National Mortgage Association), shall name as insured the Association, the Owners and Declarant (so long as Declarant is an Owner of any Units), and all Mortgagees as their respective interests may appear, and shall provide that any proceeds be paid to the Association for the use and benefit of the Owners and Mortgagees as their interest may appear. Such policy shall not be required to insure the personal property or customized items within any individual Units, which shall be and remain the responsibility and risk of the Owners.

002-47-2325

9.8.3 Additional Association Insurance The Association may purchase such other insurance as it may deem necessary, including without limitation plate-glass insurance, worker's compensation, directors liability, and errors and omissions insurance, and the Association shall purchase fidelity coverage against dishonest acts by any directors, managers, trustees, employees or volunteers of the Association who are responsible for handling funds belonging to or administered by the Association. The fidelity bond insurance shall name the Association as the insured and shall provide coverage in an amount of not less than one and one-half (1-1/2) times the Association's estimated annual operating expenses and reserves. In connection with such coverage, an appropriate endorsement to the policy to cover any persons who serve without compensation shall be added if the policy would not otherwise cover volunteers.

9.8.4 Choice of Carriers; Insurance Premiums The insurance policies required under this Section 9.8 shall meet the requirements of and be acquired from carriers meeting the qualifications of the Federal Home Loan Mortgage Corporation and the Federal National Mortgage Association. Insurance premiums shall be a Common Expense to be included in the Assessments levied by the Association. The acquisition of insurance by the Association shall be without prejudice to the right of any Owner to obtain additional individual insurance. The insurance requirements, as now existing or as may subsequently be amended from time to time, of the aforesaid Mortgage Associations are incorporated into this Declaration by reference as if copied herein verbatim.

9.8.5 Association as Attorney-in-Fact This Declaration does hereby make mandatory the irrevocable appointment of an attorney-in-fact to deal with the Project, in whole or in part, upon its destruction, repair, condemnation or other involuntary taking.

002-47-2326

Title to any Unit is declared and expressly made subject to the terms and conditions hereof, and acceptance by any grantee of a deed or other instrument of conveyance from the Declarant or from any Owner or grantor shall constitute appointment of the attorney-in-fact herein provided. All Owners irrevocably constitute and appoint the Association as their true and lawful attorney in their name, place, and stead for the purpose of dealing with said Project upon its destruction or condemnation, in whole or in part, as is herein provided. As attorney-in-fact, the Association, by and through its President or any Vice President and Secretary or any Assistant Secretary, shall have full and complete authorization, right and power to make, execute and deliver any contract, deed or any other instrument with respect to the interest of an Owner which is necessary and appropriate to exercise the powers herein granted. Any repair, reconstruction or replacement made of the improvement(s) shall be to substantially the same condition existing prior to the damage, with each Unit and the Common Elements having substantially the same vertical and horizontal boundaries as before. The proceeds of any insurance collected shall be available to the Association for the purposes of repair, restoration or replacement unless the Owners agree not to rebuild in accordance with the provisions hereinafter set forth. The Association shall have full authority, right and power, as attorney-in-fact, to cause any repair and restoration of the improvement(s) permitted or required hereunder.

Without limitation on the generality of the foregoing, the Association as said attorney-in-fact shall have the full power and authority to purchase and maintain such insurance, to collect and remit the premiums therefor, to settle and compromise any and all claims under said insurance policies, to collect proceeds and to distribute the same to the Association, the Owners and their respective Mortgagees (subject to the provisions hereof) as their interests may appear, to execute releases of liability and to execute all documents and to do all things on behalf of such Owners, the Association and the Project as shall be necessary or convenient to the accomplishment of the foregoing; and any insurer may deal exclusively with the Association in regard to such matters. The Association shall not be responsible for procurement or maintenance of any insurance covering the contents or the interior of any Unit or for the liability of any Owner for occurrences therein not caused by or in connection with the Association's operation, maintenance or use of the Project.

002-47-2327

9.8.6 Reconstruction or Repair of Project In the event of fire, casualty or other disaster involving substantial damage to the Project, within ten (10) days of receipt of determination of the amount of insurance proceeds available to the Association, the Association shall cause notice to be given of a special meeting of Owners to be held not less than twenty (20) nor more than thirty (30) days from the giving of such notice. Such notice shall specify the amount of insurance proceeds available, the estimated cost of restoration and any other data deemed pertinent to the determination called for by this Section 9.8.6.

9.8.6.1 Sufficient Proceeds In case of fire, casualty or any other disaster, the insurance proceeds, if sufficient to reconstruct the Project, shall, subject to the provisions of Sections 9.8.6.3 and 9.8.6.4 below, be applied to such reconstruction. Reconstruction of the Project, as used in this Section 9.8.6 means restoring the Project to substantially the same condition in which it existed immediately prior to the fire, casualty or other disaster, with each Unit and the Common Elements having substantially the same vertical and horizontal boundaries as before. Such reconstruction shall be caused to be accomplished by the Association or its duly authorized agents.

9.8.6.2 Insufficient Proceeds If the insurance proceeds are insufficient to reconstruct the Project, damage to or destruction thereof shall, subject to the provisions of Sections 9.8.6.3 and 9.8.6.4 below, be promptly caused to be repaired and restored by the Association or its duly authorized agents, using proceeds of insurance, if any, on the Project for that purpose, and the Owners shall be liable for the special Assessment or Assessments for any deficiency as hereinafter provided.

002-47-2328

9.8.6.3 Less than two-thirds Destruction

If less than two-thirds (2/3) of the Project (as determined by the vote or written consent of Owners owning at least fifty-one percent (51%) of the Common Interest in the exercise of their sole discretion) is destroyed or substantially damaged by fire or any other disaster, then the Project shall be rebuilt or repaired, unless the members of the Association by unanimous vote or written consent, and fifty-one percent (51%) of the Institutional Lenders (based upon one vote for each Mortgage owned) by prior written approval elect not to repair such damage.

9.8.6.4 Two-thirds or More Destruction

If two-thirds (2/3) or more of the Project (as determined by the vote or written consent of Owners owning at least fifty-one percent (51%) of the Common Interest in the exercise of their sole discretion), is destroyed or substantially damaged by fire or any other disaster, and if the members, by unanimous vote or written consent, do not voluntarily within one hundred eighty (180) days after determination of the amount of the Association's insurance proceeds resulting from such destruction or damage, make provision for reconstruction (unless within such period the buy-out contemplated in this Section 9.8.6.4 is effected), the condominium regime shall be deemed to have been waived, and the Association shall take all action required under the Act to regroup and merge the filial estate with the principal property, whereupon:

(i) the Project shall be deemed to be owned in common by the Owners;

(ii) The undivided interest in the Project owned in common which shall appertain to each Owner shall be the percentage of undivided interest previously owned by such Owner in the Common Elements;

02-47-2329

(iii) any liens on each Unit and that certain portion of the Common Elements appurtenant thereto, shall be deemed to be transferred in accordance with their existing priorities to the undivided interest of the Owner of the affected Unit; and

(iv) the Project shall be subject to an action for partition at the suit of any Owner, in which event the net proceeds of sale, together with the net proceeds of the insurance on the Project, if any, shall be considered as one fund and shall be divided among all the Owners and their mortgagees as their interests shall appear in a percentage equal to the Common Interest previously owned by each Owner.

Notwithstanding the foregoing provisions hereof, in the event of destruction or substantial damage to two-thirds (2/3) or more of the Project sixty-six and two-thirds percent (66-2/3%) of the Institutional Lenders (based upon one vote for each Mortgage owned) by written approval and the Owners may, by an affirmative vote of the Owners owning at least three-fourths (3/4) of the undivided Common Interest, at a meeting of the Owners duly called for such purpose, elect to sell or otherwise dispose of the Project. Such action shall be binding upon all Owners and it shall thereupon become the duty of every Owner to execute and deliver such instruments and to perform all acts as in manner and form may be necessary to effect the sale.

Notwithstanding the foregoing provisions hereof, in the event that two-thirds (2/3) or more of the Project has been damaged and unanimous vote has not been obtained for reconstruction at the meeting held in accordance with the provisions of the first paragraph of this Section 9.8.6.4, the Association may, by affirmative vote of the Owners owning at least three-fourths (3/4) of the undivided Common Interest at a meeting of the Members duly called for such purpose, elect to purchase all the ownership interests in the Project of those Owners not voting to rebuild. Such action will be binding upon the Association and all Owners, and it shall thereupon become the duty of the Association and every Owner to execute and deliver such instruments and to perform all acts in such manner and form as may be necessary to effect the sale and purchase.

002-47-2330

The purchase price for the ownership interest of each Owner so being purchased shall be payable to the Owner and the Owner's mortgagees as their interests shall appear and shall be an amount equal to the Owner's percentage interest in the Association's insurance proceeds plus an amount equal to the Owner's percentage interest in an amount equal to the then market value of the Project, considered as a whole, excluding such insurance proceeds and less the amount of any liens against the Project or any part thereof. In the event the parties are unable to agree upon the purchase price, the price shall be determined by appraisal as follows: The Association shall select one MAI designated appraiser to act for it; within thirty (30) days of the Association's appointment of an appraiser, the selling Owners shall appoint an MAI designated appraiser to act for them; forthwith the two appraisers acting together shall select a third independent MAI designated appraiser by mutual agreement; and the three appraisers by a vote of the majority of the group shall determine the purchase and sale price with respect to each Owner selling hereunder. All such purchases and sales shall be closed within sixty (60) days subsequent to the determination of the purchase and sale price as aforesaid, with the Association financing the same in accordance with Section 9.9. Within fifteen (15) days of the last such closing, the Association shall cause to be held a special meeting of Owners for the purpose of securing approval of reconstruction.

9.8.7 Repair of Interior of Unit Each Owner shall be responsible for the reconstruction, repair or replacement of that portion of the interior of his Unit which the Owner has installed, furnished or provided, including but not limited to, any floor coverings, wall coverings, window shades, draperies, furniture, furnishings, decorative light fixtures or other improvements, betterments and additions to his Unit, and all appliances located therein irrespective of whether or not such appliances are "built-in" to the Unit, except the original built-in appliances. Each Owner shall also be responsible for the costs not otherwise covered by insurance carried by the Association of any reconstruction, repair or replacement of any portion of the Project necessitated by his negligence or misuse or the negligence or misuse by his family, guests, agents, servants, employees or contractors. In the event damage to all or any part of the interior of an Owner's Unit is covered by insurance held by the Association for the benefit of such Owner, then such Owner shall begin

02-47-233i

reconstruction or repair of such damage upon receipt of the insurance proceeds or any portion thereof. For the Association, subject to the rights of the Association to supervise, approve or disapprove such reconstruction or repair during the course thereof. In the event damage to all or any part of the interior of an Owner's Unit is not covered by insurance held by the Association for the benefit of such Owner, then such Owner shall begin reconstruction or repair of his Unit within sixty (60) days after the date of such damage, subject to the right of the Association to supervise, approve or disapprove such reconstruction or repair during the course thereof.

9.8.8 Application of Insurance Proceeds As soon as possible after the occurrence of a casualty which causes damage to any part of the Project for which the Association has insurance coverage (hereinafter referred to as the "Casualty"), the Association shall obtain reliable and detailed cost estimates of the following:

9.8.8.1 The cost of restoring all damage caused by the Casualty to the Common Elements (hereinafter referred to as the "Common Element Costs"); and

9.8.8.2 The costs of restoring that part of the damage caused by the Casualty to each Unit which is or would be covered by insurance held by the Association without regard to the policy limits of such insurance (hereinafter referred to as the "Unit Costs"). All insurance proceeds available to the Association with respect to the Casualty shall first be applied to the payment of the actual Common Element Costs and the balance thereof, if any, shall thereafter be applied to the payment of the actual Unit Costs. However, if such insurance proceeds are not sufficient to cover such estimated costs, then a special Assessment or Assessments shall be made against the Owners by the Association in the following manner:

(i) All Owners shall be assessed on the basis of their undivided percentage interest in the Common Elements for the payment of the estimated Common Element Costs not otherwise paid for by insurance held by the Association.

002-47-2332

(ii) Each Owner of a Damaged Unit shall be assessed an amount equal to the difference between the actual portion of estimated Unit Costs attributable to his Unit less a sum calculated by multiplying the amount, if any, of the remaining insurance proceeds held by the Association with respect to the Casualty by a fraction, the numerator of which is the actual portion of the estimated Unit Costs attributable to his Unit and the denominator of which is the total of all of the estimated Unit Costs.

9.8.9 Condemnation General Provisions If all or any part of the Project is taken or threatened to be taken by condemnation, eminent domain, or by any other similar power, the Board and each Owner shall be entitled to participate in proceedings incident thereto at their respective expense. The Board shall give notice of the existence of such proceeding to all Owners and Mortgagees who have notified the Association in writing of their interest in a Unit. The expense of participation in such proceedings by the Board shall be borne as a Common Expense. The Board is specifically authorized to obtain and pay for such assistance from attorneys, appraisers, architects, engineers, expert witnesses, and other persons as the Board in its discretion deems necessary or advisable to aid or advise it in matters relating to such proceedings. All damages or awards for any such taking shall be deposited with the Board, acting as Trustee, and such damages or awards shall be applied or paid as provided herein.

9.8.9.1 Common Elements; Limited Common Elements Not Subject to Exclusive Use. In the event that an action in eminent domain is brought to condemn a portion of the Common Elements, or any Limited Common Elements that are not exclusively limited to the use of the Owner of one Unit (hereafter in this Section 9.8.9.1, all references to Limited Common Elements shall be deemed to be references only to such Limited Common Elements) the Board shall have the sole authority to determine whether to defend or resist any such proceeding; to make any settlement with respect thereto; or to convey such property to the condemning authority in lieu of such condemnation proceeding. With respect to any such taking of Common Elements or Limited Common Elements, all damages and awards shall be determined for such taking as a whole and not for each Owner's interest therein. After the damages or awards for such taking are determined, such damages or awards shall be paid to each Owner in proportion to his Common Interest. The Board may, if it

002-47-2333

deems advisable, call a meeting of the Association, at which meeting the Members, by a majority vote, shall decide whether to replace or restore as far as possible the Common Elements or such Limited Common Elements so taken or damaged.

9.8.9.2 Taking of Less than Two-Thirds of Units and Limited Common Elements Subject to Exclusive Use. In the event that any eminent domain proceeding results in the taking of or damage to one or more, but less than two-thirds of the total number of Units or those Limited Common Elements reserved for the exclusive use of the Owner of one Unit (hereafter in this Section 9.8.9.2 only, all references to Limited Common Elements shall be deemed to be references only to such Limited Common Elements), or both, then the damages and awards for such taking and the payment thereof shall be determined in accordance with the following:

(i) The Board shall determine which of the Units damaged by such taking may be made tenable and which Limited Common Elements may be made usable for the purposes set forth in this Declaration.

(ii) The Board shall determine whether it is reasonably practicable to operate the remaining Units and Limited Common Elements (including those which may be made tenable or usable) in the manner provided in this Declaration.

(iii) If the Board determines that it is not reasonably practicable to operate such remaining Units and Limited Common Elements, then the Project shall be deemed to be regrouped and merged into a single estate owned jointly in undivided interest by all Owners, as tenants-in-common, in their respective Common Interests, and the condominium regime hereby established shall terminate.

(iv) If the Board determines that it will be reasonably practicable to operate such remaining Units and Limited Common Elements, then the damages and awards made with respect to each Unit and Limited Common Element which has been determined to be capable of being made tenable or usable shall be applied to the repair and reconstruction thereof. If the cost of such work exceeds the amount of the award,

012-47-2334

The additional funds required shall be assessed against the Owners of those Units which are being repaired or reconstructed so as to be made tenable and against those Owners who have the exclusive right of use of the Limited Common Elements being made usable. With respect to those Units and Limited Common Elements which may not be made tenable or usable, the award made with respect thereto shall be paid to the Owner who owns such Unit or has the exclusive right of use of the Limited Common Elements, or to their Mortgagee, as their interests may appear, and the remaining portion of such Units and Limited Common Elements, if any, shall become a part of the Common Elements and the repair and use thereof shall be determined by the Board. Those Units which may not be made tenable shall no longer be a part of the Project and the Common Interest appurtenant to each remaining Unit or the Project shall be adjusted by the Board, according to Section 9.16, to distribute the ownership of the undivided interest in the Common Elements among the reduced number of Owners. After making such adjustment the Board will cause an instrument reflecting the new Common Interest appurtenant to each Unit to be duly recorded.

9.8.9.3 Taking of Two-Thirds of Units and Limited Common Elements Subject to Exclusive Use. If the entire Project is taken, or two-thirds or more of the Units and Limited Common Elements subject to exclusive use are taken or damaged by such taking, all damages and awards shall be paid to the accounts of the Owners thereof (or the Owners entitled to such exclusive use), in proportion to their Common Interests and the condominium regime hereby established shall terminate upon such payment. Upon such termination, the Units, Common Elements, and Limited Common Elements shall be deemed to be regrouped and merged into a single estate owned in undivided interest by all Owners, as tenants-in-common, in their respective Common Interests.

9.8.9.4 Payment of Awards and Damages. Any damages or awards provided in this Article to be paid to or for the account of any Owner by the Board, acting as Trustee, shall be applied first to the payment of any taxes or assessments by governmental authorities past due and unpaid with respect to that Unit; secondly, to amounts due under any Mortgages; thirdly, to the payment of any unpaid assessments or special assessments charged to or made against the Unit; and finally to the Owner of such Unit.

072-47-2335

9.8.10 Personal Liability Insurance. In addition to the master policies which the Association shall carry, the Board shall have the power to require each Owner, at his sole cost and expense, to carry personal liability insurance covering damage to property or injury to the person of others within the Project resulting from negligence of the Owner or his agents, tenants, guests or invitees, in an amount up to, and including, One Hundred Thousand Dollars (\$100,000.00) for each occurrence.

9.8.11 Waiver of Subrogation; Notice of Cancellation All property and liability insurance carried by the Association or the Owners shall contain provisions whereby the insurer waives rights of subrogation as to the Association, officers, and directors, and any members, their guests, agents and employees. All policies of hazard insurance must contain or have attached the standard mortgage clause commonly accepted by private institutional mortgage investors in the area in which the Units are located. All insurance carried by the Association shall contain a provision requiring the insurer to notify all insureds, including servicers on behalf of PHLMC and FNMA, named at least ten (10) days in advance of the effective date of any reduction in or cancellation of the policy.

9.9 Financing of Purchase of Unit by Association In the event the Association should acquire a Unit at foreclosure or pursuant to Section 9.8.6.4, such acquisition by the Association may be made from the working capital of the Association and common charges in the hands of the Association, or if such funds are insufficient, the Association may levy a special Assessment or Assessments against each Owner in proportion to his Common Interest, as a Common Expense, or the Association, in its discretion, may borrow money to finance the acquisition of such Unit; provided, however, that no financing may be secured by an encumbrance or hypothecation of any property other than the Unit, together with the interest in the Common Elements appurtenant thereto, so to be acquired by the Association.

9.10 Limitation of Restrictions on Declarant Declarant is performing certain work in connection with the development of the Property into a condominium regime. The completion of that work and the sale, rental, and other disposition of said Units is essential to the establishment and welfare of the Project as a residential community. In order that said work may be completed and said Project be established as a fully occupied residential community as rapidly as possible, nothing in this Declaration shall be understood or construed to:

9.10.1 Prevent Declarant, its contractors, or sub-contractors from doing on or to the Project or any Unit, whatever is reasonably necessary or advisable in connection with the completion of the work; or

002-47-2336

9.10.2 Prevent Declarant or its representatives from erecting, constructing and maintaining on any part or parts of the Project, such structures as may be reasonable and necessary for the conduct of its business of completing said work and establishing said Project as a residential community and disposing of the same in parcels by sale, lease or otherwise; or

9.10.3 Prevent Declarant from conducting on any part of the Project its business of completing the work and of establishing a plan of Unit ownership and of disposing of said Project in Units by sale, lease or otherwise; or

9.10.4 Prevent Declarant from maintaining such sign or signs on any part of the Project as may be necessary for the sale, lease or disposition thereof.

So long as Declarant owns one or more of the Units established and described in this Declaration (and except as otherwise specifically provided herein), Declarant, its successors and assigns, shall be subject to the provisions of this Declaration.

9.11 Termination of Any Responsibility of Declarant
Declarant may at any time, or from time to time, sell, assign or transfer all or any part of its rights hereunder and/or its rights, title and interest in the Project to any Person or Persons who shall thereafter have such rights and powers of Declarant as are contained in the Project Documents and so transferred or assigned. In the event Declarant shall convey all of its right, title and interest in and to the Project to any Person or Persons, then and in such event, Declarant shall be relieved of the performance of any further duty or obligation hereunder, and such Person or Persons shall be obligated to perform all such duties and obligations of the Declarant.

9.12 Owners' Compliance The Association and each Owner, tenant or occupant of a Unit and their guests and invitees shall comply with the provisions of the Project Documents and all lawful decisions and resolutions of the Association or its duly authorized representative, and failure to comply with any such provisions, decisions, or resolutions, shall be grounds for an action by the Association or any aggrieved Owner to recover sums due for damages (including costs and reasonable attorneys' fees) and/or for injunctive relief. All agreements and determinations lawfully made by the Association in accordance with the voting percentages established in this Declaration or in the Bylaws, shall be deemed to be binding on the Association all Owners, their successors and assigns.

002-47-2337

9.13 Legal Intent. It is the intent of Declarant, the Association and the Owners that the Project Documents be in strict compliance with applicable usury laws of the State of Texas. In furtherance thereof, said parties stipulate and agree that none of the terms and provisions contained in the Project Documents shall ever be construed to create a contract to pay for the use, forbearance or detention of money, interest at a rate in excess of the maximum interest rate permitted to be charged by applicable laws of the State of Texas. The Owners or other parties now or hereafter becoming liable for payment of sums owing under the terms of the Project Documents shall never be liable for unearned interest on any of said sums and shall never be required to pay interest at a rate in excess of the maximum interest that may be lawfully charged under applicable laws of the State of Texas, and the provisions of this Section shall control over all other provisions of the Project Documents in conflict herewith. In the event that the Declarant, the Association or any of its designated agents shall collect monies which are deemed to constitute interest at a rate in excess of that permitted to be charged by applicable laws of the State of Texas, all such sums deemed to constitute interest in excess of the legal rate shall be immediately returned to the Owner or other party so paying said monies upon such determination.

9.14 Conflict of Project Documents If there is any conflict among or between the Project Documents, the provisions of this Declaration shall prevail; thereafter, priority shall be given to Project Documents in the following order: Map; Articles; Bylaws; and Rules and Regulations of the Association.

9.15 Term of Declaration The covenants, conditions, and restrictions of this Declaration shall run with and bind the Property and the Project, and shall inure to the benefit of and shall be enforceable by the Association, its respective legal representatives, successors-in-interest and permitted assigns, for a term of fifty (50) years from the date of this Declaration is recorded, after which time said covenants, conditions, and restrictions shall automatically be extended for successive periods of ten (10) years, unless an instrument, signed by all of the then Owners and all of the then Mortgagees, has been recorded, agreeing to change said covenants, conditions, and restrictions in whole or in part.

002-47-2338

9.16 Reallocation of Interests In the event of a partial condemnation or partial destruction of the Project wherein the interest of one or more Owners is terminated, voluntarily or involuntarily, then and in such event such terminated Owner's (or Owners') Common Interest shall be reallocated to the remaining Units pursuant to the following formula, to wit:

- A - remaining individual Unit's Common Interest prior to this reallocation
- B - total Common Interest of all remaining Units prior to reallocation
- C - remaining individual Unit's Common Interest after reallocation

A divided by B = C

Notwithstanding the foregoing paragraph of this Section 9.16, in the event of a partial destruction and buy-out pursuant to Section 9.8.6.4 of this Declaration wherein a certain Unit (or Units) is to be rebuilt, then and in such event such Unit shall retain its Common Interest share in the pro rata reallocation of the Common Interest appurtenant to any Units not rebuilt, all as is provided in the first paragraph of this Section 9.16.

9.17 Abandonment or Termination Except for abandonment or termination as provided herein in the case of substantial destruction by fire or other casualty or in the case of a taking by condemnation or eminent domain, the condominium regime established hereby shall not be abandoned or terminated without consent of all Unit Owners and of all Mortgagees. In the event of such a unanimous and voluntary abandonment or termination, the Project shall be deemed to be owned in common by the Owners; the undivided interest in the Project owned in common which shall appertain to each Owner shall be the percentage of undivided interest previously owned by such Owner in the Common Elements; any liens on each Unit and that certain portion of the Common Elements appurtenant thereto, shall be deemed to be transferred in accordance with their existing priorities to the undivided interest of the Owner of the affected Unit; and the Project shall be subject to an action for partition at the suit of any Owner, in which event the net proceeds of the sale together with the net proceeds of the sale of any property of the Association, and any cash or other funds held by the Association, if any, shall be considered as one fund and shall be divided among all the Owners and their mortgagees as their interest shall appear in a percentage equal to the Common Interest previously owned by each Owner.

002-47-2339

9.18 NOTICE OF PROXIES Any proxies to be effective must be filed with the Secretary or Assistant Secretary of the Association. Any prospective grantee from a Unit owner, upon payment to the Association of a reasonable fee not to exceed Twenty-Five and no/100 Dollars (\$25.00) and upon written request, shall be entitled to a statement from the Association setting forth whether or not a given Unit owner has granted such a proxy as shown by the records of the Secretary or Assistant Secretary of the Association. If the prospective grantee's grantor or predecessor(s) in title has given such a proxy, filed as previously set forth, then any such grantee takes his ownership interest and membership in the Association subject to the proxy and said proxy shall continue in full force and effect as if such grantee had granted the proxy to the holder thereof.

002-47-2340

The undersigned, being the Declarant herein, has
executed this Declaration on August 3, 1903.

DECLARANT: POUNDER FOREST, INC.

By: *[Signature]*

H. R. Cleveland, President

Attest:

[Signature]
Secretary

002-47-2341

THE STATE OF TEXAS
COUNTY OF GALVESTON

On August 3, 1983, before me, the undersigned, a Notary Public in and for said County and State, personally appeared H.R. Cleveland, known to me to be the President of PONDEROSA FOREST, INC., whose name is subscribed to the within Declaration and Master Deed, and known to me to be the person and officer who executed the within instrument on behalf of such Corporation, as the act and deed of such Corporation, and acknowledged to me that he executed such instrument for the purposes and consideration set forth therein and in the capacity therein stated, pursuant to the Corporation's Bylaws or a resolution of its Board of Directors.

WITNESS my hand and official seal.

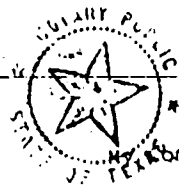

Debbie Moody
NOTARY PUBLIC IN AND FOR
THE STATE OF TEXAS

DEBBIE MOODY
NOTARY PUBLIC - GALVESTON COUNTY FOR THE STATE OF TEXAS
MY COMMISSION EXPIRES 4-26, 1984

My Commission Expires:

002-47-2342

DESCRIPTION OF A 319,539.38 SQUARE FOOT TRACT OUT OF LOTS 3, 4, AND 5,
SCHMIDT ENCLOSURE PARTITION, GALVESTON COUNTY, TEXAS

According to the map or plat recorded in Volume 763, Page 624 in the
Office of the County Clerk of Galveston County, Texas.

BEGINNING at the South corner of Lot 5, same being the East corner of
Lot 4, said point lying in the Northwest right of way line of Sunset Street;

THENCE from said beginning corner N51°48'E, along the North right of way
of Sunset Street, a distance of 174.5 feet to a point for corner in the
North right of way line of Sunset Street;

THENCE N38°12'W along the Northeasterly line of Lot 5 and the Southwesterly
line of Lot 6, a distance of 1501.53 feet to a point for corner;

THENCE S88°19'W, a distance of 9.91 feet to a point for corner;

THENCE S88°24'W, a distance of 37.0 feet to a point for corner to a point
for corner;

THENCE N88°03'W, a distance of 54.1 feet to a point for corner;

THENCE N89°35'W, a distance of 114.6 feet to a point for corner;

THENCE N86°56'W, a distance of 25.3 feet to a point for corner;

THENCE South, a distance of 286.95 feet to a point for corner;

THENCE East, a distance of 203.50 feet to a point for corner;

THENCE S24°43'50"E, a distance of 142.50 feet to a point for corner;

THENCE S63°46'13"E, a distance of 252.00 feet to a point for corner;

THENCE S51°48'W, a distance of 45.00 feet to a point for corner in the
Southwesterly line of Lot 5 and the Northeasterly line of Lot 4;

THENCE S38°12'E, along the common line of Lot 4 and 5, a distance of
935.26 feet to the place of beginning and containing 319,539.38 square
feet, more or less.

PONDEROSA FOREST, INC.

002-47-2343

RECORDER'S MEMORANDUM.
At the time of recording, this instrument was found to be inadequate for the best photographic reproduction because of illegibility, carbon or photo copy, discolored paper, etc. All blockouts, additions and changes were present at the time this instrument was filed and recorded.

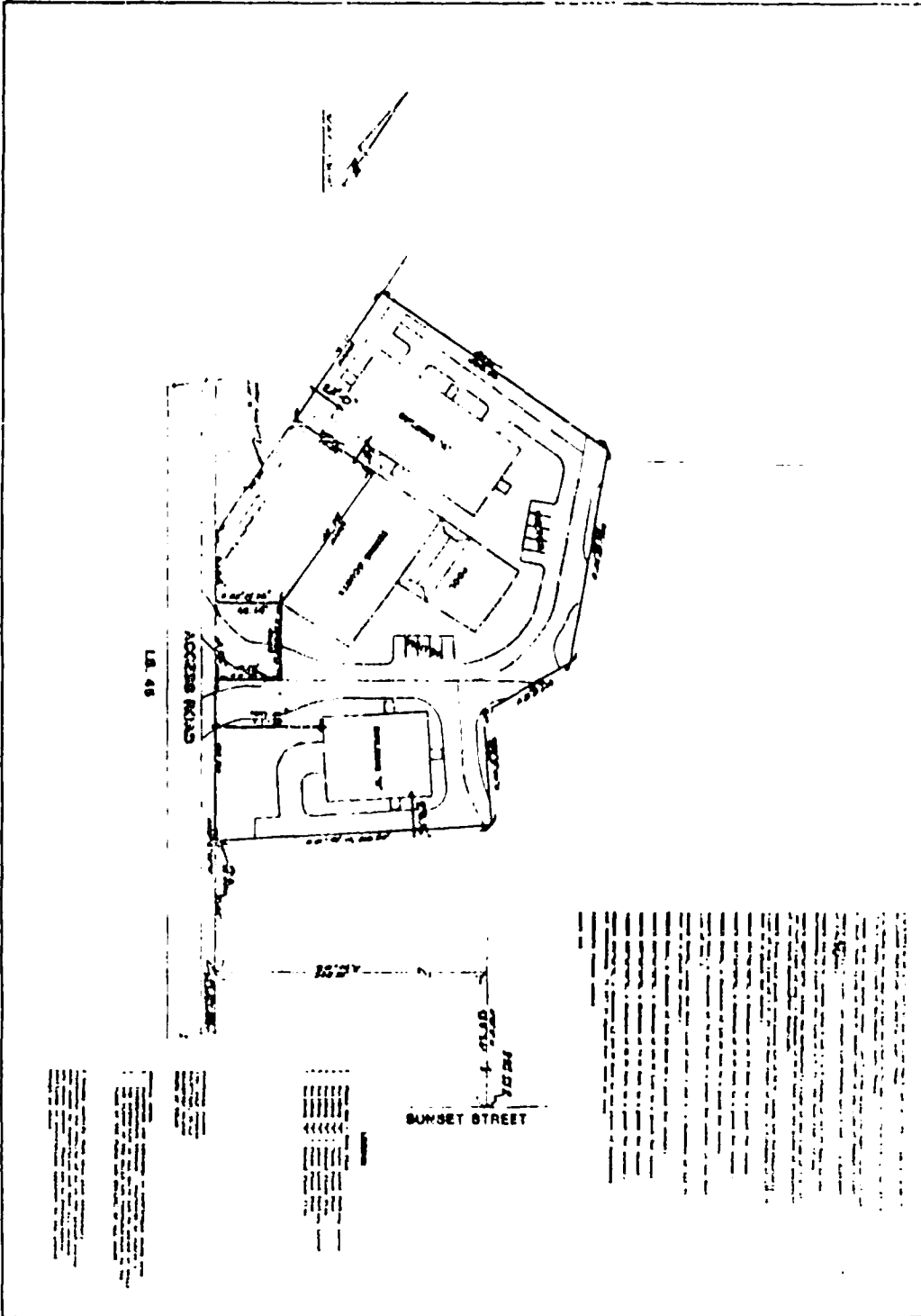

 	GULF COAST ENGINEERING AND SURVEYING P.O. BOX 322 LA HABRA, TEXAS 77044 PHYSICAL ADDRESS: 21 ST 028111 LA HABRA, TEXAS 77044 PHONE: 281-291-1111 FAX: 281-291-1112	PONDEROSA FOREST PHASE ONE
	<small>PLANNED BY: GULF COAST ENGINEERING AND SURVEYING DATE: 08/15/01</small>	

002-47-2345

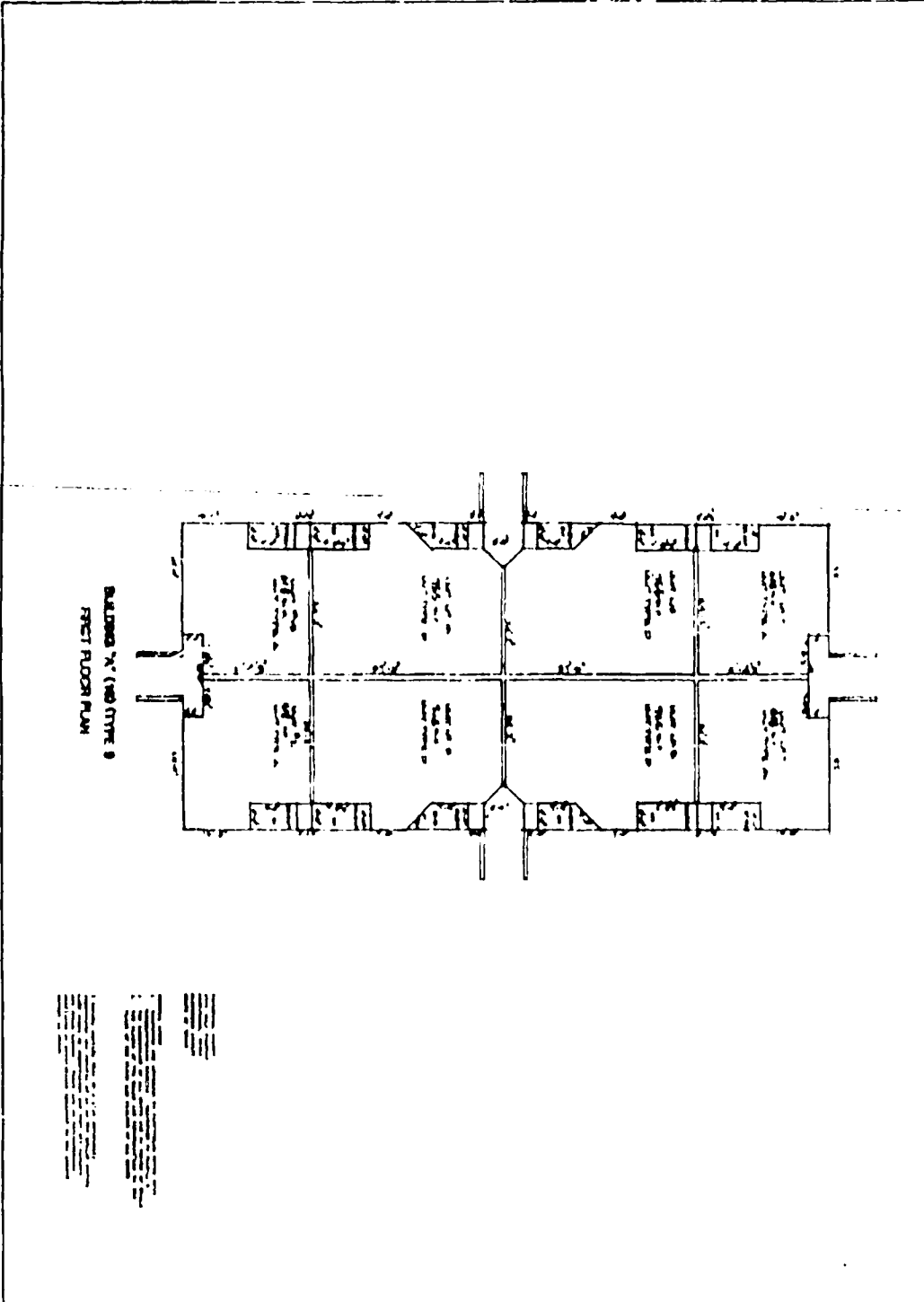

BUILDING NO. (18) TYPE 8
FIRST FLOOR PLAN

Vertical text block containing several lines of small, illegible text, likely a legend or notes for the floor plan.

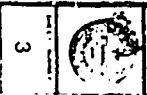

GULF COAST ENGINEERING
AND SURVEYING
P.O. BOX 1372 - LA MARSHALL, FLORIDA 32568
AND 110 EAST PALM AVENUE - TAMPA, FLORIDA 33604
TELEPHONE 813-281-1111

PONDEROSA FOREST
PHASE ONE

Printed text at the bottom center of the page, likely a title or reference number.

002-47-2347

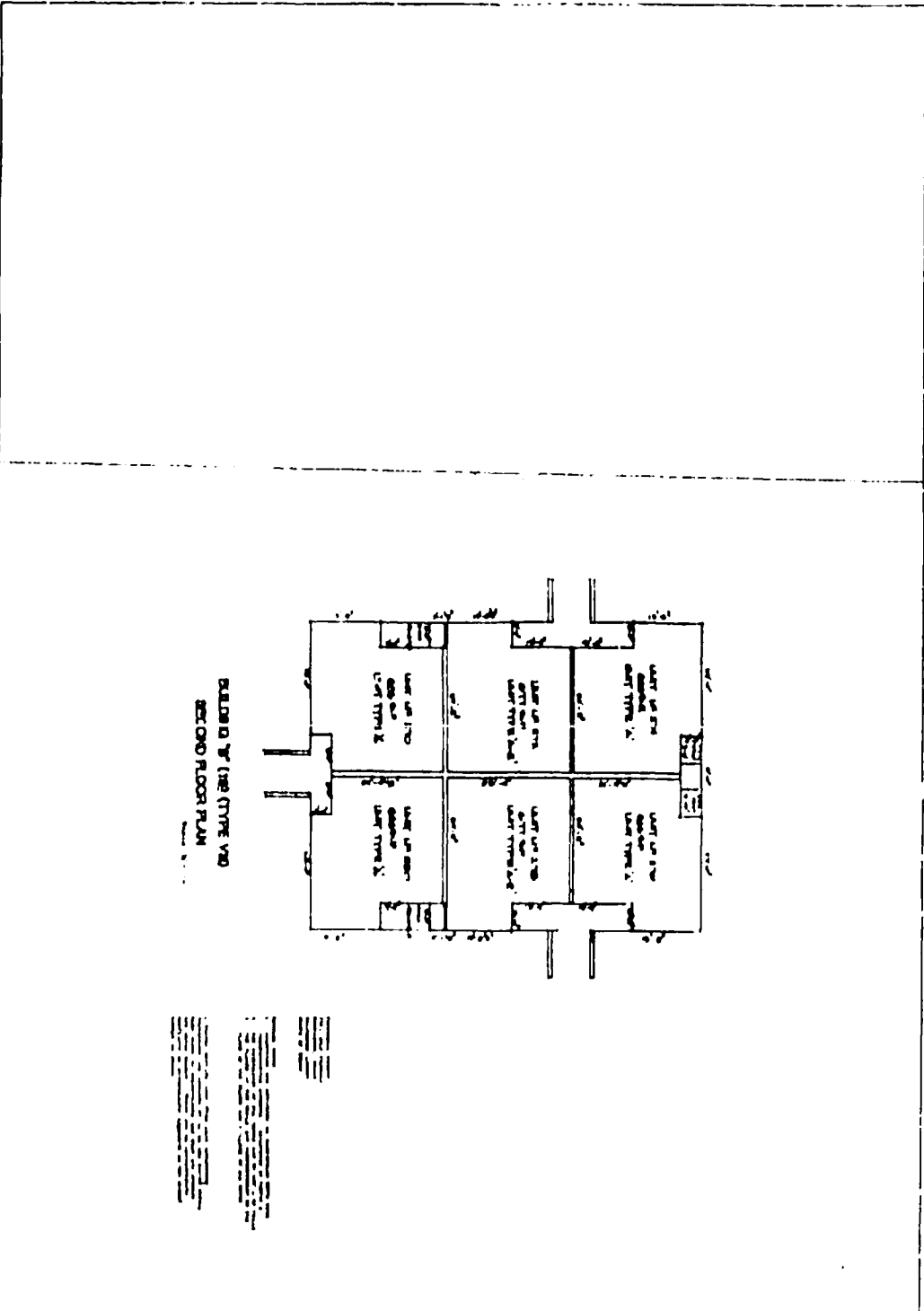

BUILDING 'B' (18) (TYPE 'A')
SECOND FLOOR PLAN

UNIT 101
 UNIT 102
 UNIT 103
 UNIT 104
 UNIT 105
 UNIT 106

7	 	GULF COAST ENGINEERING AND SURVEYING <small>PO BOX 152 LA MARQUE, TEXAS 77640</small>	PONDEROSA FOREST PHASE ONE
		<small> LICENSE NO. 6749 EXPIRES 12/31/88 REGISTERED PROFESSIONAL ENGINEER STATE OF TEXAS </small>	<small> DRAWING NO. 100-100-100 SHEET NO. 100-100-100 DATE 10/10/88 </small>

Scale: 1/8" = 1'-0"

002-47-2348

BUILDING 5 (118) TYPE 110
5331 FLOOR PLAN

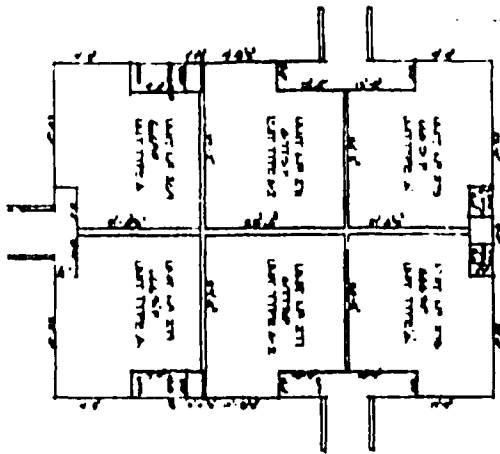

Vertical text or notes, possibly a legend or scale, located below the floor plan.

6		GULF COAST ENGINEERING AND SURVEYING		PONDEROSA FOREST PHASE ONE
		15 MARION, TEXAS 77546		

EXHIBIT B BY G.C.E.S.

002-47-2349

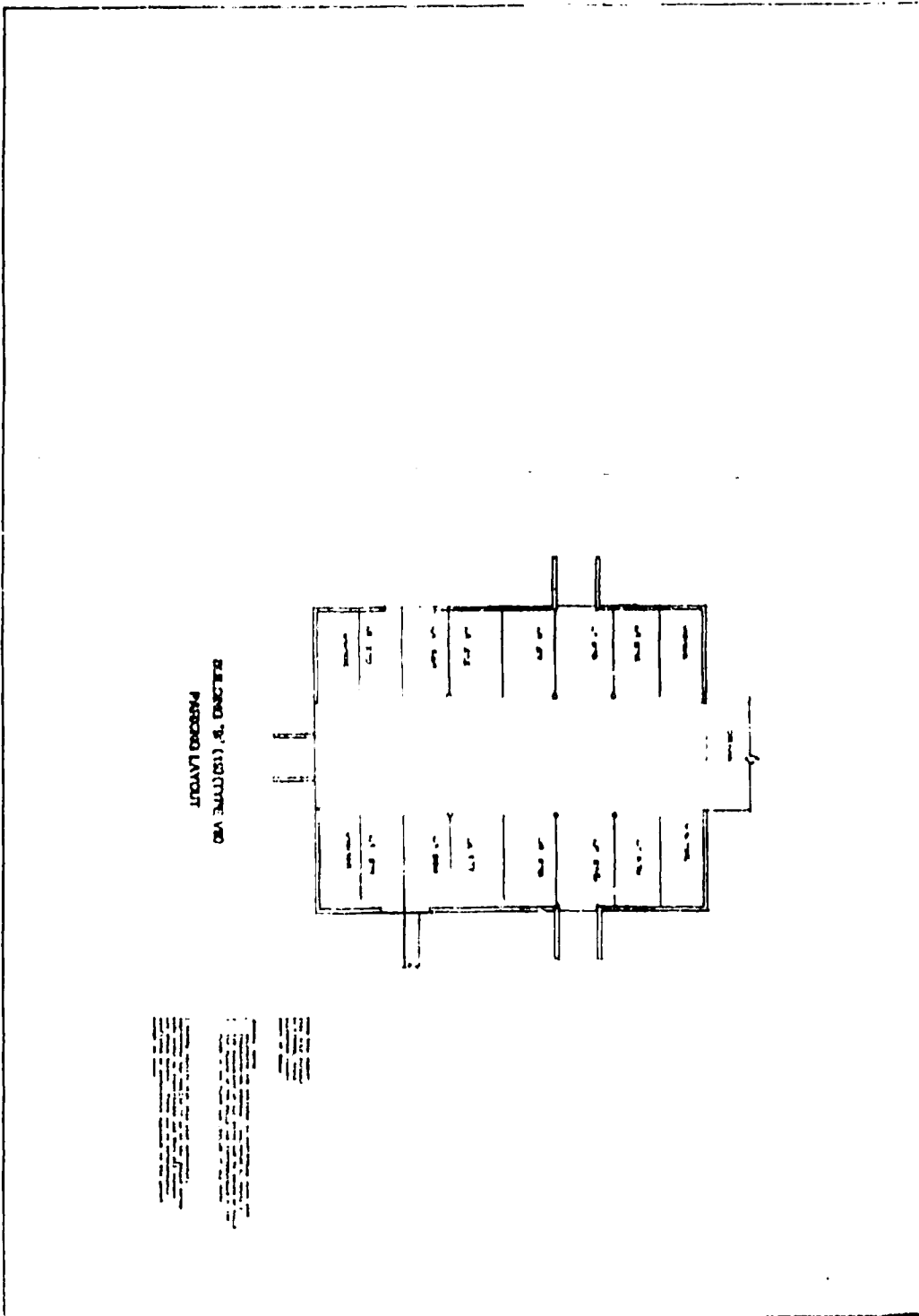

BUILDING 7 (133) OFFICE YARD
PONDOSA LAYOUT

[Faded text, likely a legend or notes]

5			GULF COAST ENGINEERING AND SURVEYING
			<small>REGISTERED PROFESSIONAL ENGINEER REGISTERED PROFESSIONAL SURVEYOR STATE OF TEXAS</small>

**PONDEROSA FOREST
PHASE ONE**

002-47-2349

EXHIBIT "C"
POMEROSA FOREST CONDOMINIUMS
PERCENTAGE OWNERSHIP INTEREST IN COMMON ELEMENTS

002-47-2350

PHASE I
BUILDING A

<u>UNIT NO.</u>	<u>PERCENTAGE OWNERSHIP INTEREST</u>
1	2.996
2	2.996
3	4.635
4	4.635
5	4.635
6	4.635
7	2.996
8	2.996
9	2.996
10	2.996
11	4.635
12	4.635
13	4.635
14	4.635
15	2.996
16	2.996

PHASE I
BUILDING B

<u>UNIT NO.</u>	<u>PERCENTAGE OWNERSHIP INTEREST</u>
269	3.226
270	3.226
271	3.286
272	3.286
273	3.226
274	3.226
275	3.226
276	3.226
277	3.286
278	3.286
279	3.226
280	3.226

TOTAL PERCENTAGE 100.0002

002-47-2351

BYLAWS
OF
PONDEROSA FOREST
HOMEOWNERS ASSOCIATION, INC.
A NON-PROFIT CORPORATION

The name of this non-profit corporation shall be Ponderosa Forest Homeowners Association, Inc. (the "Association").

ARTICLE I.

PURPOSE AND PARTIES

1. The purpose for which the Association is formed is to govern the condominium regime known as Ponderosa Forest Condominiums, situated in the County of Galveston, State of Texas, which property is described in that certain Declaration and Master Deed ("Declaration"), and which property shall be submitted to the regime created by the Texas Condominium Act by the recording of the Declaration and the Exhibits thereto, including a true and correct copy of these Bylaws. All definitions and terms contained in said Declaration shall apply hereto and are incorporated hereby by reference.

2. All present or future Owners, tenants, future tenants of any unit, or any other person who might use in any manner the facilities of the Project are subject to the provisions and any regulations set forth in these Bylaws. The mere acquisition lease or rental of any Unit or the mere act of occupancy of a Unit will signify that these Bylaws are accepted, approved, ratified, and will be complied with.

ARTICLE II.

MEMBERSHIP, VOTING MAJORITY OF

OWNERS, QUORUM, PROXIES

1. Membership Except as is otherwise provided in these Bylaws, ownership of a Unit is required in order to qualify for membership in this Association. Any person on becoming an owner of a Unit shall automatically become a Member of this Association and be subject to these Bylaws.

002-47-2352

Such membership shall terminate without any formal Association action whenever such person ceases to own a Unit, but such termination shall not relieve or release any such former Owner from any liability or obligation incurred under or in any way connected with this Association during the period of such ownership and membership in this Association, or impair any rights or remedies which the Owners have, either through the Board of Directors of the Association or directly against such former Owner and Member arising out of or in any way connected with ownership and membership and the covenants and obligations incident thereto.

2. Voting Each Unit shall be entitled to one vote (regardless of the number of Owners of such Unit), the value of such one vote shall equal the Common Interest assigned to the respective Unit, as set forth in Exhibit "C" to the Declaration. This one vote can not be partitioned or the value of such vote divided among the Owners of a Unit. If more than one Person is the record holder of fee simple title of a Unit, then any one such Person may act, including vote, on behalf of all such Persons. In the event two or more Persons, who are record holders of fee simple title of an interest in a given Unit, attempt to act or vote on behalf of said Unit, then the Board, in its sole discretion shall determine and designate which Person shall so act or vote on behalf of such Unit.

3. Majority of Owners As used in these Bylaws, the term "Majority of Owners" shall mean those Owners, entitled to vote holding fifty-one percent (51%) of the Common Interest.

4. Quorum Except as otherwise provided in these Bylaws, the presence in person or by proxy of fifty-one percent (51%) of the Common Interest of the Owners entitled to vote shall constitute a quorum. In the event a quorum is not present, then the meeting called shall be adjourned, and notice of a new meeting for the same purposes within two (2) to four (4) weeks shall be sent by mail, at which subsequent meeting the number of Owners entitled to vote represented in person or by proxy shall be sufficient to constitute a quorum.

5. Proxies Votes may be cast in person or by written proxy. No proxy shall be valid after eleven (11) months from the date of its execution unless specifically provided in the proxy. All proxies must be filed with the Secretary or Assistant Secretary of the Association before the appointed time of each meeting.

6. Vote Required Unless required otherwise in the Declaration or Articles, an affirmative vote of a Majority of Owners present, either in person or by proxy, shall be required to transact the business of the meeting of the Association.

02-47-2353

ARTICLE III.

ADMINISTRATION

1. Association Responsibilities The Owners will constitute the Association which will have the responsibility of administering the Project through a Board of Directors. In the event of any dispute or disagreement between any Owners relating to the Project, or any questions of interpretation or application of the provisions of the Project Documents, such dispute or disagreement shall be submitted to the Board. The determination of such dispute or disagreement by the Board shall be binding on each and all such Owners, subject to the right of Owners to seek other remedies provided by law after such determination by the Board.

2. Place of Meeting Meetings of the Association shall be held at such suitable place, convenient to the Owners, as the Board of Directors may determine.

3. Annual Meetings The first meeting of the Association shall be held within sixty (60) days after the date on which the Declarant's control of the Association ends. Thereafter, the annual meetings of the Association shall be held on or before forty-five (45) days after the expiration of the prior fiscal year. At such meetings there shall be elected by ballot of the Owners a Board of Directors in accordance with the requirements of Paragraph 5 of Article IV of these Bylaws. The Owners may also transact such other business of the Association as may properly come before them.

4. Special Meetings It shall be the duty of the President to call a special meeting of the Owners as directed by resolution of the Board of Directors or upon a petition signed by a majority of Owners and having been presented to the Secretary or Assistant Secretary of the Association. The notice of any special meeting shall state the time and place of such meeting and the purpose thereof. No business except as stated in the notice shall be transacted at a special meeting. Any such meetings shall be held after the first annual meeting and shall be held within thirty (30) days after receipt by the President of such resolution or petition.

5. Notice of Meetings It shall be the duty of the Secretary or Assistant Secretary of the Association to mail a notice, postage prepaid, of each annual or special meeting, stating the purpose thereof as well as the time and place it is to be held, to each Owner of record at such Owner's last known address and to each Institutional Lender (who may designate a representative to attend such meetings), at least ten (10) days, but not more than thirty (30) days prior to such meeting. The mailing of a notice in the manner provided in this paragraph shall be considered notice served.

W2-47-2354

6. Order of Business The order of business at all meetings of the Owners of the Project shall be as follows:

- (a) Roll call and certifying proxies;
- (b) Proof of notice of meeting or waiver of notice;
- (c) Reading and disposal of unapproved minutes;
- (d) Reports of officers;
- (e) Reports of committees;
- (f) Election of directors;
- (g) Unfinished business;
- (h) New business; and
- (i) Adjournment.

ARTICLE IV.

BOARD OF DIRECTORS

1. Number and Qualification Until the first meeting of the Association, the affairs of this Association shall be governed by an Initial Board of Directors consisting of the three (3) persons delineated in the Articles of Incorporation of the Association or as later appointed by Declarant. Such Initial Directors need not be Owners. At such first meeting, there shall be elected by secret written ballot any five (5) Members of the Association to the Board of Directors who shall thereafter govern the affairs of this Association until their successors have been duly elected and qualified or until such Director ceases, voluntarily or involuntarily, to be an Owner. At such election, the Owners entitled to vote or their proxies may cast, in respect to each vacancy, as many votes as they are entitled to exercise under the provisions of the Declaration and these Bylaws. The person receiving the largest value of votes shall be elected. Cumulative voting is not permitted.

2. Powers and Duties The Board of Directors shall have the powers and duties necessary for the administration of the affairs of the Association and for the operation and maintenance of a residential condominium project in keeping with the character and quality of the neighborhood in which it is located. The Board of Directors may do all such acts and things except as by law or by these Bylaws or by the Declaration may not be delegated to the Board of Directors.

3. Other Powers and Duties Such powers and duties of the Board of Directors shall include, but shall not be limited to, the following, all of which shall be done for and in behalf of the Owners of the Condominiums:

- (a) To administer and enforce the covenants, conditions, restrictions, easements, uses, limitations, obligations and all other provisions set forth in the Declaration, the Bylaws of the Association and supplements and amendments thereto.

02-47-2355

(b) To establish, make and enforce compliance with such reasonable rules and regulations as may be necessary for the operation, use and occupancy of the Project with the right to amend same from time to time. A copy of such rules and regulations shall be delivered or mailed to each Owner promptly upon the adoption thereof.

(c) To acquire, construct, manage, maintain and keep in good order, condition and repair all of the General and Limited Common Elements and all items of common personal property used by the Owners in the enjoyment of the entire premises, except as such duty may be specifically designated herein to each Owner.

(d) To insure and keep insured all of the insurable General Common Elements of the Project in an amount equal to their maximum replacement value as provided in the Declaration. Maximum replacement value shall be determined annually by one or more written appraisals. Further, to obtain and maintain comprehensive public liability insurance as provided in the Declaration. To insure and keep insured all of the fixtures, equipment and personal property acquired by the Association for the benefit of the Association and the Owners of the Units and their Mortgagees. The limits and coverage shall be reviewed at intervals of not less than one (1) year and adjusted, if necessary, to provide such coverage and protection as the Association may deem prudent. So long as the Federal Home Loan Mortgage Corporation (FHLMC) and/or the Federal National Mortgage Association (FNMA) is a Mortgagee of a Unit in the Project, or owns a unit therein, the Association shall maintain in effect at least such casualty, flood and liability insurance a fidelity bond, meeting standards established in the FHLMC "Servicer's Guide" and the FNMA Conventional Home Mortgage Selling Contract Supplement or otherwise, except to the extent such requirements shall have been waived in writing by FHLMC and/or FNMA. Worker's compensation insurance shall at all time be carried to the extent required to comply with any applicable law with respect to the employees, if any, of the Association.

Each Owner may obtain additional insurance at his own expense for his own benefit. Insurance coverage on the furnishings and other personal property belonging to an Owner and casualty and public liability insurance coverage within each Unit are specifically made the responsibility of each Owner.

002-47-2356

(e) To Prepare a Common Expense Budget for the Project, at least annually; to determine the amount of common charges payable by the Owners to meet the Common Expenses and to allocate and assess such amounts among the Owners according to the Declaration and these Bylaws; by a majority vote of the Board to decrease or increase the amount of the monthly Assessments; to levy and collect special Assessments whenever, in the opinion of the Board, it is necessary to do so in order to meet increased operating or maintenance expenses or costs, or additional capital expenses, or because of emergencies.

(f) To collect delinquent assessments by suit or otherwise and to enjoin and seek damages from an Owner who may be in default as is provided in the Declaration and these Bylaws. To provide for and enforce a per diem late charge and to collect interest.

(g) To protect and defend the entire Project from loss and damage by suit or otherwise.

(h) To borrow funds in order to pay for any expenditure or outlay required pursuant to authority granted by the provisions of the Declaration and these Bylaws, and to execute all such instruments evidencing such indebtedness as the Board of Directors may deem necessary. Such indebtedness shall be the several obligation of all of the Owners in the same proportion as their Common Interests.

(i) To enter into contracts within the scope of their duties and powers.

(j) To establish a bank account or accounts for the common treasury and for all separate funds which are required or may be deemed advisable by the Board of Directors.

(k) To make repairs, additions, alterations and improvements to the Common Elements consistent with managing the Project in a manner in keeping with the character and quality of the neighborhood in which it is located, the best interests of the Owners and the Declaration and these Bylaws.

(l) To keep and maintain full and accurate books and records showing all of the receipts, expenses or disbursements and to permit examination thereof at any reasonable time by each of the Owners, and to cause a complete audit of the books and accounts by a certified or public accountant, once each year.

002-47-2357

(m) To prepare and deliver annually to each Owner a statement showing receipts, expenses and disbursements since the last such statement.

(n) To meet at least once each quarter; provided that any Board of Directors meeting may be attended and conducted by telephone or other device which permits all of the Directors in attendance to participate in such meeting, and provided further that any action required to be taken at any meeting of the Board of Directors, or any action which may be taken at such meeting, may be taken without a meeting if a consent in writing, setting forth the action so taken, shall be signed by all of the members of the Board.

(o) To designate the personnel necessary for the maintenance and operation of the General and Limited Common Elements.

(p) In general, to carry on the administration of this Association and to do all of those things necessary and reasonable in order to carry out the governing and the operation of this Project.

(q) The Board of Directors may employ for the Association a management agent (Managing Agent) who may be delegated and shall exercise some or all of the powers granted to the Board of Directors by the Declaration and By-laws as determined by the Board, except for the powers of attorney-in-fact set forth in the Declaration.

Any agreement for professional management of the Project, or any other contract providing for services by the Declarant, must have a maximum contract term of one (1) year and must provide for termination by either party without cause or payment of a termination fee on thirty (30) days or less written notice.

(r) To prepare and file annual tax returns with the federal government and to make such elections as may be necessary to reduce or eliminate the tax liability of the Association. Without limiting the generality of the foregoing, the Board may, on behalf of the Association, elect to be taxed under Section 528 of the Internal Revenue Code or any successor

002-47-2358

statute conferring benefits on owners' associations are in effect from time to time. Initially the Board shall comply with the following limitations and restrictions:

(i) At least sixty percent (60%) of the gross income of the Association for any taxable year shall consist solely of amounts received as membership dues, fees, or assessments from Unit Owners;

(ii) At least ninety percent (90%) of the expenditures of the Association for any taxable year shall be for the acquisition, construction, management, maintenance, and care of Association property;

(iii) No part of the net earnings of the Association shall inure (other than by acquiring, constructing, or providing management maintenance, and care of Association property and other than by a rebate of excess membership dues, fees, or assessments) to the benefit of any private Member or individual. In addition, the Board shall take such steps as are necessary to insure that substantially all of the Units will be used as residences.

4. No Waiver of Rights The omission or failure of the Association or any Owner to enforce the covenants, conditions, restrictions, easements, uses, limitations, obligations or other provision of the Declaration, the Bylaws or the rules and regulations adopted pursuant thereto, shall not constitute or be deemed a waiver, modification or release thereof, and the Board of Directors or the Managing Agent shall have the right to enforce the same thereafter.

5. Election and Term of Office At the first meeting of the Association the term of office of three (3) Directors shall be fixed at two (2) years; and the term of office of two (2) Directors shall be fixed at one (1) year. At the expiration of the initial term of office of each respective Director, his successor shall be elected to serve a term of two (2) years. The Directors shall hold office until their successors have been elected and hold their first meeting, except as is otherwise provided.

002-47-2359

5. Vacancies Vacancies in the Board of Directors caused by death, resignation or disqualification, and by any reason other than the removal of a Director by a vote of the Association shall be filled by vote of the majority of the remaining Directors, even though they may constitute less than a quorum; and each person so elected shall be a Director until a successor is elected at the next annual meeting of the Association.

7. Removal of Directors Prior to the first Annual Meeting of the Association the Directors may not be removed by the Association. At any regular or special meeting duly called, any one or more of the Directors may be removed with or without cause by a majority of Owners, and a successor may then and there be elected to fill the vacancy thus created. Any Director whose removal has been proposed by the Owners shall be given an opportunity to be heard at the meeting.

8. Organization Meeting The first meeting of a newly elected Board of Directors following the annual meeting of the Owners shall be held within ten (10) days thereafter at such place as shall be fixed by the Directors at the meeting at which such Directors were elected, and no notice shall be necessary to the newly elected Directors in order legally to constitute such meeting, providing a majority of the whole Board shall be present.

9. Regular Meetings and Notice Regular meetings of the Board of Directors may be held at such time and place as shall be determined, from time to time, by a majority of the Directors but at least one such meeting shall be held during each calendar quarter. Notice of regular meetings of the Board of Directors shall be given to each Director, personally or by mail, telephone or telegraph, at least five (5) days prior to the day named for such meeting.

10. Special Meetings Special meetings of the Board of Directors may be called by the President on five (5) days notice to each Director, given personally or by mail, telephone or telegraph, which notice shall state the time, place (as hereinabove provided) and purpose of the meeting. Special meetings of the Board of Directors shall be called by the President or Secretary or Assistant Secretary of the Association in like manner and on like notice on the written request of one or more Director.

11. Waiver of Notice Before or after any meeting of the Board of Directors, any Director may, in writing, waive notice of such meeting and such waiver shall be deemed equivalent to the giving of such notice. Attendance by a Director at any meeting of the Board shall be a waiver of notice by him of the time and place thereof. If all the Directors are present at any meeting of the Board, no notice shall be required and any business may be transacted at such meeting.

002-47-2360

12. Board of Directors' Quorum. At all meetings of the Board of Directors, a majority of the Directors shall constitute a quorum for the transaction of business.

13. Fidelity Bonds. The Board of Directors shall require that all officers and employees of the Association or of the Managing Agent, if any, handling or responsible for Association funds shall furnish fidelity bonds in accordance with the Declaration. The premiums on such bonds shall be a Common Expense.

14. Compensation. No member of the Board of Directors shall receive any compensation for acting as such.

15. Vote Required. Unless required otherwise in the Declaration or Articles an affirmative vote of a majority of the Directors present in person shall be required to transact the business of the meeting of the Board and constitute an act of the Board.

16. Action Taken Without A Meeting. The Directors shall have the right to take any action without a meeting which they could take at a meeting by obtaining the written approval of all the Directors. Any action so approved shall have the same effect as though taken at a meeting of the Board of Directors.

17. Procedure. The Board of Directors shall keep regular minutes of its proceedings. The minutes shall be placed in a minute book of the Association.

ARTICLE V.

FISCAL MANAGEMENT

The provision for fiscal management of the Project for and in behalf of all of the Owners as set forth in the Declaration shall be supplemented by the following provisions:

1. Accounts. The funds and expenditures of the Owners by and through the Association shall be credited and charged to accounts under the following classifications as shall be appropriate, all of which expenditures shall be Common Expenses:

(a) Current expense, which shall include all funds and expenditures within the year for which the funds are budgeted, including a reasonable allowance for contingencies and working funds, except expenditures chargeable to reserves and to additional improvements.

(b) Reserve for deferred maintenance, which shall include funds for maintenance items which occur less frequently than annually.

W2-47-2361

(e) Reserve for replacement (sinking fund), which shall include funds for replacement required because of damage, wear or obsolescence.

7. Fiscal Year The fiscal year for the Association shall be the calendar year.

ARTICLE VI.

OFFICERS

1. Designation The officers of the Association shall be a President, a Vice-President, a Secretary, and a Treasurer, all of whom shall be elected by the Board of Directors, and such assistant officers as the Board of Directors shall, from time to time, elect. Such officers need not be members of the Board of Directors, but each shall be either an Owner of a Unit or, if the Owner is a firm, partnership, corporation, association or other legal entity, the authorized representative of such entity, or the Declarant or his representative(s). The Office of President and Treasurer may be held by the same person, and the office of Vice-President and Secretary or Assistant Secretary may be held by the same person.

2. Election of Officers The officers of the Association shall be elected annually by the Board of Directors at the organizational meeting of each new Board and shall hold office subject to the continuing approval of the Board.

3. Resignation and Removal of Officers Upon an affirmative vote of a majority of the members of the Board of Directors, any officer may be removed, either with or without cause, and his successor elected at any regular meeting of the Board of Directors, or at any special meeting of the Board called for such purpose. Any officer may resign at any time by giving written notice to the Board, the President or the Secretary. Such resignation shall take effect on the date of receipt of such notice or at any later time specified therein, and unless otherwise specified therein, the acceptance of such resignation shall not be necessary to make it effective.

4. Vacancies A vacancy in any office because of the death, resignation, removal, disqualification or otherwise of the officer previously filling such office may be filled by appointment by the Board and continue subject to the approval of the Board.

002-47-2362

5. President The President shall be the chief executive officer of the Association. He shall preside at all meetings of the Association and of the Board of Directors. He shall have all of the general powers and duties which are usually vested in the office of president of an association, including but not limited to the power to appoint committees from among the Owners from time to time as he may in his discretion decide is appropriate to assist in the conduct of the affairs of the Association or as may be established by the Board or by the Members of the Association at any regular or special meetings.

6. Vice-President The Vice-President shall have all the powers and authority and perform all the functions and duties of the President, in the absence of the President, or his inability for any reason to exercise such powers and functions or perform such duties, and also perform any duties he is directed to perform by the President.

7. Secretary The Secretary shall keep all the minutes of the meeting of the Board of Directors and the minutes of the Association; he shall have charge of such books and papers as the Board of Directors may direct; and he shall, in general, perform all the duties incident to the office of Secretary and as is provided in the Declaration and the Bylaws.

The Secretary shall compile and keep up to date at the principal office of the Association a complete list of Owners and their last known addresses as shown on the records of the Association. Such list shall also show opposite each Owner's name the number or other appropriate designation of the Unit owned by such Owner, the undivided percentage interest in the Common Elements of such Owner and a description of the Limited Common Elements assigned for exclusive use in connection with such Unit. Such list shall be open to inspection by Owners and other persons lawfully entitled to inspect the same at reasonable times during regular business hours.

8. Assistant Secretary The Assistant Secretary, if any, shall have all the powers and authority to perform all the functions and duties of the Secretary in the absence of the Secretary or in the event of the Secretary's inability for any reason to exercise such powers and functions or to perform such duties, and also to perform any duties he is directed to perform by the Secretary.

9. Treasurer The Treasurer shall receive and deposit in appropriate bank accounts all money of the Association and shall disburse such funds as directed by resolution of the Board of Directors; provided, however, that a resolution of the Board of Directors shall not be necessary for disbursements made in the ordinary course of business conducted within the limits of a budget adopted by the Board

002-47-2363

of Directors; sign all checks and promissory notes of the Association; keep proper books of account; cause an annual statement of the Association's books to be made at the completion of each fiscal year; prepare an annual budget and a statement of income and expenditures to be presented to the membership at its regular annual meeting, and deliver a copy of each to the Members; and perform all other duties assigned to him by the Board of Directors. In the event a Managing Agent has the responsibility of collecting and disbursing funds, the Treasurer shall review the accounts of the Managing Agent within fifteen (15) days after the first day of each month.

ARTICLE VII.

INDEMNIFICATION OF OFFICERS,
DIRECTORS AND MANAGING AGENT

1. Indemnification The Association shall have the power to indemnify any Officer or Director thereof and the Declarant, who was or is a party, or is threatened to be made a party, to any threatened, pending or completed action, suit or proceeding, whether civil, criminal, administrative, or investigative (whether or not by or in the right of the Association) by reason of the fact that such person is or was a Director or Officer of the Association, against all loss, expenses (including but not limited to attorney's fees and costs of the proceeding), judgments, fines and amounts paid in settlement actually and reasonably incurred by him in connection with or in defense of such action, suit or proceeding if such person acted in good faith and in a manner which such person reasonably believed to be in or not opposed to the best interests of the Association; provided, that with respect to: (1) any criminal action or proceeding, such person had no reasonable cause to believe that his conduct was unlawful; or (2) any civil claim, issue or matter, such person shall not be guilty of gross negligence or willful misconduct in the performance of his duties to the Association. Termination of any action, suit, or proceeding by judgment, order, settlement, conviction, or upon a plea of nolo contendere or its equivalent, shall not, of itself, create a presumption that such person had reasonable cause to believe that his conduct was unlawful, that such person did not act in good faith or in a manner which he reasonably believed to be in or not opposed to the best interests of the Association, or that such person is guilty of gross negligence or willful misconduct in the performance of his duties to the Association, all such matters being determined solely and exclusively for the purpose of indemnification as herein provided.

002-47-2364

Indemnification under the preceding paragraph shall be made by the Association only so authorized in each specific case upon the determination that indemnification of such person is proper in the circumstances because he has met the applicable standards of conduct as set forth herein. Such determination shall be made (1) by the Board of Directors by a majority vote of a quorum consisting of Directors who were not parties to such action, suit or proceeding; or (2) if such a quorum is not obtainable by (a) independent legal counsel in a written opinion, or (b) the Members of the Association and no Member shall be disqualified from voting because he is or was party to any such action, suit or proceeding. Indemnification so determined may be paid, in part, before the termination of such action, suit or proceeding upon the receipt by the Association of an undertaking by or on behalf of the person claiming such indemnification to repay all sums so advanced if it is subsequently determined that he is not entitled thereto as provided in this Article.

To the extent that a Director or Officer of the Association has been successful on the merits or otherwise in the defense of any action, suit or proceeding, whether civil or criminal, such person shall be indemnified against such expenses (including costs and attorneys' fees) actually and reasonably incurred by him in connection therewith.

Indemnification provided herein shall be exclusive of any and all other rights and claims to which those indemnified may be entitled as against the Association, and every Director, Officer or employee thereof under any Bylaws, resolution, agreement or law and any request for payment hereunder shall be deemed a waiver of all such other rights, claims or demands as against the Association and each Director, Officer and employee thereof. The indemnification provided herein shall inure to the benefit of the heirs, executors, administrators and successors of any person entitled thereto under the provision of this Article.

The Association shall purchase and maintain insurance on behalf of any person who is or was a Director, Officer, employee or agent of the Association against any liability asserted against him and incurred by him in any such capacity, or arising out of his status as such, whether or not the Association would have the power to indemnify him against such liability under the provision of this Article.

All liability, loss, damage, cost and expense incurred or suffered by the Association by reason or arising out of or in connection with the foregoing indemnification

002-47-2365

provisions shall be treated and handled by the Association as Common Expenses provided, however, that nothing in this Article VII contained shall be deemed to obligate the Association to indemnify any Member or Owner of a Unit who is or has been a director or officer of the Association with respect to any duties or obligations assumed or liability incurred by him under and by virtue of the Declaration and these Bylaws that were assumed or incurred outside of his conduct specifically related to the fulfillment of his duties as an Officer or Director of the Association.

2. Other The Board of Directors, Officers or the Managing Agent shall enter contracts or other commitments as agents for the Association, and they shall have no personal liability for any such contract or commitment (except such liability as may be ascribed to them in their capacity as Owners), provided, however, that such exclusion of personal liability shall apply to the Managing Agent only so long as it is acting within its scope of authority, and the liability of any Owner on such contract or commitment shall be limited to such proportionate share of the total liability thereof that the Common Interest of each Owner bears to the aggregate Common Interest of all of the Owners as set forth in Exhibit "C" of the Declaration.

ARTICLE VIII:

AMENDMENTS TO BYLAWS

1. Amendments to Bylaws These Bylaws may be amended in writing by the majority of Owners; provided, however, that such authority may be delegated by the majority of Owners to the Board as allowed by the Texas Non-Profit Corporation Act.

ARTICLE IX.

EVIDENCE OF OWNERSHIP, REGISTRATION OF MAILING ADDRESS

AND DESIGNATION OF VOTING REPRESENTATIVE

1. Proof of Ownership Except for those Owners who purchase a Unit from Declarant, any person, on becoming an Owner of a Unit, shall furnish to the Managing Agent or Board of Directors a true and correct copy of the original or a certified copy of the recorded instrument vesting that person with an interest or ownership in the Unit, which copy shall remain the files of the Association. A Member shall not be deemed to be in good standing nor shall he be entitled to vote at any annual or special meeting of Members unless this requirement is first met.

002-47-2366

2. Registration of Mailing Address The Owner or several Owners of an individual Unit shall designate and the name registered mailing address to be used by the Association, for mailing of monthly statements, notices, demands and all other communications, and such registered address shall be the only mailing address of a person or persons to be used by the Association. Such registered address of an Owner or Owners shall be deemed to be the mailing address of the Unit owned by said Owner or Owners unless a different registered address is furnished by such Owner (s) to the Managing Agent or Board of Directors within fifteen (15) days after transfer of title, or after a change of address; and such registration shall be in written form and signed by all of the Owners of the Unit or by such person as are authorized by law to represent the interest of (all of) the Owner(s) thereof.

3. Designation of Voting Representative-Proxy If a Unit is owned by one individual, his right to vote shall be established by the record title thereto. If title to a Unit is held by more than one individual or by a firm, corporation, partnership, association, or other legal entity, or any combination thereof, such Owners shall execute a proxy appointing and authorizing one individual or alternate individuals to attend all annual and special meetings of Members and thereat to cast whatever vote the Owners themselves might collectively cast if they were personally present. Such proxy shall be effective and remain in force unless voluntarily revoked, amended or sooner terminated by operation of law; provided, however, that no proxy shall be valid after eleven (11) months from the date of execution unless specifically provided therein. Also, within thirty (30) days after such revocation, amendment or termination, the Owners shall reappoint and authorize one individual or alternate individuals to attend all annual and special meetings as provided by this Paragraph 3.

The requirements herein contained in this Article IX shall be first met before an Owner of a Unit shall be deemed in good standing and entitled to vote at an annual or special meeting.

ARTICLE X.

OBLIGATIONS OF THE OWNERS

1. Assessments

(a) Monthly Assessments Assessments shall be due monthly in advance on the first day of each month. After monthly Assessments have been set by the Board of Directors, the Board of Directors shall prepare and deliver or mail to each Owner an individual statement of the Owner's monthly Assessment; thereafter, monthly statements shall be prepared and delivered or mailed only in the event of a change in the monthly Assessment, the levying of a special Assessment or in the event an Owner becomes delinquent in payment of the monthly Assessments.

002-47-2357

The Assessments made for Common Expenses shall be based upon the cash requirements deemed to be such aggregate sum as the Board of Directors of the Association determines is to be paid by all of the Owners, including the Declarant, to provide for the payment of all estimated expenses growing out of or connected with the maintenance, repair, operation, additions, alterations and improvements of and to the Common Elements, which sum may include, but shall not be limited to: expenses of management; taxes and special assessments until separately assessed; premiums for fire insurance with extended coverage and vandalism and malicious mischief with endorsements attached issued in the amount of the maximum replacement value of all of the Units (including all fixtures, interior walls and partitions, decorated and finished surfaces of perimeter walls, floors and ceilings, doors, windows and other elements or materials comprising a part of the Units); casualty and public liability and other insurance premiums; landscaping and care of grounds; common lighting; repairs and renovations; removals of pollutants and trash collections; wages; utility charges for Common Elements; beautification and decoration; professional, including legal and accounting fees (except that no Association funds may be used for the purpose of bringing suit against the Declarant, his representatives, successors or assigns), management fees, expenses and liabilities incurred by the Managing Agent or Board of Directors on behalf of the Owners under or by reason of this Declaration and the Bylaws of the Association; for any deficit arising or any deficit remaining from a previous period; the creation of a reasonable contingency fund, reserves, working capital, and sinking fund as well as other costs and expenses relating to the Common Elements. Utility expenses may increase from the amount budgeted because of rate or usage increases or fuel cost adjustments, and other budgeted line items may increase from time to time. In the event the cash requirements for utility expenses or any other recurring expense exceeds the budget amount for that particular expense line item, or in the event the cash requirements for Common Expenses exceed the aggregate assessments made pursuant to this Article, the Board of Directors for the Association may from time to time and at any time make pro rata increases in the monthly Assessments to include amounts sufficient to recoup operating budget deficits for utility expense or other recurring budget line item expenses or Common Expenses in the aggregate, as well as including increased current operating expenses. The omission or failure to fix the assessment for any period shall not be deemed a waiver, modification or a release of the Owners from their obligation to pay the same.

(b) Special Assessments In addition to those monthly assessments described in Paragraph (a) above, special Assessments may be made from time to time by the Board of Directors of the Association to meet other needs or to

002-47-2368

construct or establish facilities deemed to benefit to the Association and the Owners by the Board of Directors or to overcome deficits in the monthly operating budgets. However, there shall be no special Assessments for additions, alterations or improvements of or to the Common Elements, requiring an expenditure by the Association in excess of \$20,000 in any one calendar year without the prior approval of the majority of Owners. Such limitations shall not be applicable however, to special Assessments for the replacement, repair, maintenance or restoration of any Common Elements which are to be paid for by the Association according to the Declaration and these Bylaws and shall not be applicable to the purchase, if any, by the Association of a Unit for use as an office by the Association.

(c) Voting A Member shall be deemed in good standing and entitled to vote at any annual or special meeting of the Members, within the meaning of these Bylaws, if, and only if, he shall have fully paid all Assessments made or levied against him and the Unit owned by him.

(d) Owner's Personal Obligation for Payment of Assessments The Amount of total Assessments against each Unit shall be the personal and individual debt of the Owner thereof. The Board of Directors shall have the responsibility to take prompt action to collect any unpaid Assessment in accordance with the term of the Declaration.

2. Vendor's Lien The obligations of each Owner to pay Assessments shall be secured by a Vendor's Lien in said Owner's Deed to his Unit, said Vendor's Lien being more particularly described in Section 4.3 of the Declaration.

3. Notice of Lien or Suit An Owner shall give notice to the Association of every lien or encumbrance upon his Unit, other than for taxes and special Assessments, and notice of every suit or other proceeding which may affect the title to his Unit, and such notice shall be given within five (5) days after the Owner has knowledge thereof.

4. Owner's Maintenance and Repair

(a) Maintenance and repair shall be according to the Declaration. An Owner shall maintain and keep in repair the interior of his own Unit, including the fixtures thereof. All fixtures and equipment installed within the Unit commencing at a point where the utilities enter the Unit shall be maintained and kept in repair by the Owner thereof (unless the cost of said maintenance and repair is otherwise herein described a Common Expense). An Owner shall do no act nor omit to do any act that will impair the structural soundness or integrity of any Building or impair any easement or hereditament (nor shall he make any changes to the individual patio or balcony appurtenant to his Unit, if any).

(b) An Owner shall be obligated to reimburse the Association promptly upon receipt of its statement for any expenditures incurred by it in repairing or replacing any General or Limited Common Element damaged by his negligence or by the negligence of his tenants or agents or guests.

5. Mechanic's Lien Each Owner agrees to indemnify and to hold each of the other Owners harmless from any and all claims of mechanic's lien filed against other Units and the appurtenant Common Elements for labor, materials, services or other products incorporated in such Owner's Unit.

In the event such a lien is filed and/or a suit for foreclosure of mechanic's lien is commenced, then within ten (10) days thereafter such Owner shall be required to deposit with the Association cash or negotiable securities equal to double the amount of such claim plus interest at ten percent (10%) per annum for one (1) year together with the sum equal to ten percent (10%) of the amount of such claim, but not less than TWO HUNDRED FIFTY and 00/100 DOLLARS (\$250.00), which latter sum may be used by the Association for any costs and expenses incurred, including attorney's fees incurred for legal advice and counsel. Except as is otherwise provided, such sum or securities shall be held by the Association pending final adjudication or settlement of the claim or litigation. Disbursement of such funds or proceeds shall be made by the Association to insure payment of or on account of such final judgment or settlement. Any deficiency, including attorney's fees incurred by the Association, shall be paid forthwith by this subject Owner, and his failure to so pay shall entitle the Association to make such payment, and the amount thereof shall be a debt of the Owner, and a lien against his Unit may be foreclosed as is provided in the Declaration for non-payment of Assessments. All advancements, payments, costs and expenses, including attorney's fees, incurred by the Association shall be forthwith reimbursed to it by such Owner (s), and the Owner (s) shall be liable to the Association for the payment of interest at the rate of ten percent (10%) per annum on all such sums paid or incurred by the Association.

002-47-2370

6. General

(a) Each Owner shall comply strictly with the provisions of the recorded Declaration and these Bylaws and amendments thereto.

(b) Each Owner shall always endeavor to observe and promote the cooperative purposes for the accomplishment of which this Project was declared.

7. Use of General Common Elements and Limited Common Elements Each Owner may use the General Common Elements and Limited Common Elements in accordance with the purpose for which they were intended without hindering or encroaching upon the lawful rights of the other Owners.

8. Right of Entry

(a) An Owner shall grant the right of entry to the Managing Agent or to any other person authorized by the Association in case of an emergency originating in or threatening his Unit whether the Owner is present at the time or not.

(b) An Owner shall permit other Owners, or their representatives, to enter his Unit for the purpose of performing installations, alterations or repairs to the mechanical, electrical or utility services which, if not performed, would affect the use of other Units (s); provided that requests for entry are made in advance and that such entry is at a time convenient to the Owner. In case of an emergency, such right of entry shall be immediate.

9. Rules and Regulations

The Board of Directors, pursuant to Paragraph 3 (b) of Article IV of these Bylaws, reserves the power to establish, make and enforce compliance with such additional rules as may be necessary or desirable for the efficient and enjoyable operation, use and occupancy of this Project with the right to amend same from time to time. Copies of such rules and regulations shall be furnished to each Owner prior to the date when the same shall become effective.

ARTICLE XI.

ABATEMENT AND ENJOINMENT OF VIOLATIONS BY OWNERS

1. Abatement and Enjoinment The violation of any rule or regulation, or the breach of any Bylaw, or the breach of any provision of the Declaration, shall give the

002-47-2371

Board of Directors or the Managing Agent the right, in addition to any other rights set forth in the Declaration or herein, (1) to enter the Unit in which, or as to which, such violation or breach exists and to remove, abate and remove, at the expense of the defaulting Unit Owner, any person, structure, thing or condition that may exist therein contrary to the intent and meaning of the provisions hereof, and the Board of Directors or Managing Agent shall not be deemed guilty in any manner of trespass; and to expel, remove and put out, using such force as may be necessary in so doing, without being liable to prosecution or any damages either at law or in equity, during the continuance of any breach. No item of construction will be removed without a judicial action, in a court of competent jurisdiction notice and an opportunity for hearing given to all parties affected by any such removal.

ARTICLE XII.

COMMITTEES

1. Designation The Board of Directors may, but shall not be required to, appoint an executive committee, and it may designate and appoint members to the standing committees.

2. Executive Committee The executive committee shall consist of at least three ~~(3)~~ persons who are Members and who shall be appointed by the Board of Directors from the members of the Board. One Member shall be the President. The executive committee shall supervise the affairs of the Association and shall regulate its internal economy, approve expenditures and commitments, act and carry out the established policies of the Association and report to the Directors at each meeting of the Board. The executive committee may hold regular meetings, monthly or as it may in its discretion determine. Special meetings may be called monthly at any time by the chairman of the committee or by any of its members, either personally or by mail, telephone or telegraph, and a special meeting may be held by telephone.

3. Nominating Committee Before each annual meeting, the Board of Directors may appoint a committee of three Members who shall nominate candidates for the Board. The names of the candidates shall be submitted on or before sixty (60) days before the election. Members may submit names of candidates other than those submitted by the nominating committee at least thirty (30) days prior to the election. Unless such names are submitted, either by the nominating committee or by the Members, no person shall be elected whose name is not so submitted unless no nominations are made, in which event the names of candidates shall be submitted at the election by the Members.

4. Architectural Control and other Committees Unless and until the Declarant has appointed an Architectural Control Committee in accordance with the Declaration, the Board shall either perform the functions of the Architectural Control Committee or shall appoint (together with Declarant as provided in the Declaration) a separate

002-47-2372

Architectural Control Committee consisting of three (3) Members who shall serve concurrent one (1) year terms. In addition, the Board of Directors shall appoint other committees as deemed appropriate in carrying out its purpose.

5. Vacancies A vacancy in any committee shall be filled by the President until the next meeting of the Board of Directors.

ARTICLE XIII.

NON-PROFIT ASSOCIATION

This Association is not organized for profit. No Member, member of the Board of Directors, officer or person from whom the Association may receive any property or funds shall receive or shall be lawfully entitled to receive any pecuniary profit from the operation thereof, and in no event shall any part of the funds or assets of the Association be paid as salary or compensation to, or distributed to, or inure to the benefit of any member of the Board of Directors, officer or Member; provided, however, always (1) that reasonable compensation may be paid to any Member, director or officer while acting as an agent or employee of the Association for services rendered in effecting one or more of the purposes of the Association, and (2) that any Member, director or officer may, from time to time, be reimbursed for his actual and reasonable expenses incurred in connection with the administration of the affairs of the Association.

ARTICLE XIV.

EXECUTION OF DOCUMENTS

The Persons who shall be authorized to execute any and all contracts, documents, instruments or conveyance or encumbrances, including promissory notes, shall be two, one of each of the President or any Vice-President, and the Secretary or any Assistant Secretary of the Association.

ARTICLE XV.

PROXY TO TRUST

Owners shall have the right to irrevocably constitute and appoint their Mortgagees their true and lawful attorney to vote their Unit membership in this Association at any and all meetings of the Association and to vest in such beneficiary or his nominees any and all rights, privileges, and powers that they have as Owners under the Bylaws of this Association or by virtue of the Declaration. Such proxy shall become effective upon the filing of a notice by the beneficiary with the Secretary or Assistant Secretary of the

002-47-2373

Association at such time or times as the beneficiary shall deem its security in jeopardy by reason of the failure, neglect, or refusal of the Association, the Managing Agent, or the Owners to carry out their duties as set forth in the Declaration. Such proxy shall be valid until such time as a release of the beneficiary's deed of trust is executed and a copy thereof delivered to the Secretary or Assistant Secretary of the Association, which shall operate to revoke such proxy. Nothing herein contained shall be construed to relieve Owners or to impose upon the beneficiary of the Deed of Trust the duties and obligations of an Owner.

ARTICLE XVI.

CONFLICTING OR INVALID PROVISIONS

Notwithstanding anything contained herein to the contrary, should all or a part of any Article of these Bylaws be in conflict with the provisions of the Texas Non-Profit Corporation Act or the Texas Condominium Act, as amended, such Acts shall control; and should any part of these Bylaws be invalid or inoperative for any reason, the remaining parts, so far as is possible and is reasonable, shall be valid and operative.

ARTICLE XVII.

NOTICES

All notices to Members of the Association shall be given by delivering the same to each Owner in person or by depositing the notices in the U.S. Mail, postage prepaid, addressed to each Owner at the address last given by each Owner to the Secretary of the Association. Only one notice need be given to a Unit regardless of the number of Owners of such Unit. If an Owner shall fail to give an address to the Secretary for mailing of such notices, all such notices shall be sent to the Unit of such Owner, and all Owners shall be deemed to have been given notice of the meetings upon the proper mailing of the notices to such addresses irrespective of the actual receipt of the notices by the Owners.

By our signature hereto the undersigned, being all of the Initial Directors of the Association, hereby adopt the foregoing Bylaws for the Association as of the 1 day of August, 1983.

Charlyne Mastine
Allene Montague
Carole E. Baker

DESCRIPTION OF A 71,007.35 SQUARE FOOT TRACT OUT OF LOTS 3, AND 4, SCHMIDT ENCLOSURE PARTITION, GALVESTON COUNTY, TEXAS

According to the map or plat recorded in Volume 763, Page 624 in the Office of the County Clerk of Galveston County, Texas.

COMMENCING at the South corner of Lot 5, same being the East corner of Lot 4, said point lying in the Northwest right of way line of Sunset Street;

THENCE N38°12'W, along the common line between Lots 4 and 5, a distance of 935.36 feet;

THENCE S51°48'W, across Lots 4 and 3, a distance of 345.28 feet to the Northeasterly right of way line of I.S. 45, 300 foot right of way;

THENCE N34°18'50"W, along the Northeasterly right of way line of I.S. 45, 300 foot right of way, a distance of 96.64 feet to the place of beginning of the tract hereinafter described;

THENCE from said point continuing N34°18'50"W, along the Northeasterly right of way line of I.S. 45, 300 foot right of way, a distance of 120.36 feet to a point for corner;

THENCE N51°48'00"E, a distance of 48.25 feet to a point for corner;

THENCE N34°18'50"W, a distance of 49.69 feet to a point for corner;

THENCE North, a distance of 120.00 feet to a point for corner;

THENCE West, a distance of 70.00 feet to a point for corner in the West line of Lot 3;

THENCE North, along the West line of Lots 3 and 4, a distance of 111.00 feet to a point for corner;

THENCE East, a distance of 203.50 feet to a point for corner;

THENCE S24°43'50"E, a distance of 162.50 feet to a point for corner;

THENCE S27°14'19"W, a distance of 73.41 feet to a point for corner;

THENCE S38°12'00"E, a distance of 51.00 feet to a point for corner;

THENCE S51°45'W, a distance of 203.50 feet to the place of beginning and containing 71,007.35 square feet, more or less.

BERNARD P. ...

...

002-47-2375

PHASE TWO

DESCRIPTION OF A 46,188.01 SQUARE FOOT TRACT OUT OF LOTS 3, 4 and 5,
SCHMIDT ENCLOSURE PARTITION, GALVESTON COUNTY, TEXAS

According to the map or plat recorded in Volume 763, Page 624 in the Office
of the County Clerk of Galveston County, Texas.

COMMENCING at the South corner of Lot 5, same being the East corner of
Lot 4, said point lying in the Northwest right of way line of Sunset Street;

THENCE N38°12'W, along the common line between Lots 4 and 5, a distance
of 935.36 feet;

THENCE S51°48'W, across Lots 4 and 3, a distance of 345.28 feet to the
place of beginning of the tract hereinafter described, said beginning
point lying in the Northeasterly right of way line of I.S. 45, 300 foot
right of way;

THENCE from said beginning corner N34°18'50"W, along the Northeasterly
right of way line of I.S. 45, 300 foot right of way, a distance of 96.64
feet to a point for corner;

THENCE N51°48'00"E, a distance of 203.50 feet to a point for corner;

THENCE N38°12'00"W, a distance of 81.00 feet to a point for corner;

THENCE N27°14'19"E, a distance of 73.41 feet to a point for corner;

THENCE N24°43'50"W, a distance of 20.00 feet to a point for corner;

THENCE S63°46'13"E, a distance of 252.08 feet to a point for corner;

THENCE S54°48'W, a distance of 390.28 feet to the place of beginning
and containing 46,188.01 square feet, more or less.

PONDEROSA FOREST CONDOS

PHASE TWO

FILED FOR RECORD
AUG 25 4 10 PM '83

STATE OF TEXAS COUNTY OF GALVESTON
I hereby certify that this instrument was filed on the
date and time stamped herein by me and was duly recorded
in the Official Public Records of Real Property of Galveston
County Texas on

EXHIBIT F

AUG 25 1983



Mary Jane Christensen
COUNTY CLERK
Galveston County, Texas

Stewart D...
90

8333833

002-50-0320

FIRST AMENDMENT TO DECLARATION
AND MASTER DEED FOR
PONDEROSA FOREST CONDOMINIUMS

This amendment is made and entered into by Ponderosa Forest, Inc., a Texas corporation hereinafter referred to as "Declarant" on the date noted below.

W I T N E S S E T H

WHEREAS, PONDEROSA FOREST CONDOMINIUMS was established by the recordation of a Declaration and Master Deed for Ponderosa Forest Condominiums on the 8 day of August, 1983 at film code number 002-47-2292 of the Condominiums Records of Galveston County, Texas, said document hereinafter referred to as the "Declaration," and all other terms used herein shall have the same meaning and definition used or provided said terms in the Declaration;

WHEREAS, the Declaration provides that Declarant may add future phases as part of the condominium regime established under the Declaration without joinder or consent of any Unit Owner or any Mortgagee; and

WHEREAS, Declarant is presently the owner of all the Units in Ponderosa Forest Condominiums and the owner of the real property described in Exhibit F of this First Amendment and the Declaration together with the improvements thereon, hereinafter collectively referred to as "Phase II", and Declarant desires to add, annex and merge Phase II into the Property heretofore subject to the Declaration, all as provided in the Declaration;

002-50-0321

NOW, THEREFORE, Declarant hereby amends Phase II to the provisions of the Declaration and declares Phase II to be added, annexed and merged into the Ponderosa Forest Condominiums subject to all easements and encumbrances presently affecting said property recorded in the Official Public Real Property records of Galveston County, Texas, and upon the recording of this First Amendment, (i) all of said property described in Exhibit F attached hereto shall become a part of the condominium regime established by the Declaration and a part of the Property and (ii) in accordance with the provisions of the Declaration, the undivided percentage interest in the Common Elements appurtenant to each Unit in Ponderosa Forest Condominiums is hereby adjusted and shall be as shown in Exhibit G of this First Amendment. The Map attached as Exhibit B to the Declaration is expanded by the addition to it of the map or plat attached to this First Amendment as Exhibit H and by this reference incorporated herein for all purposes. Exhibit H depicts the locations and other data as required by the Declaration with respect to the said Phase II added to the Condominiums by this First Amendment. Declarant hereby declares that all of said property added, annexed and merged to and into the Condominiums by this First Amendment is held and shall be sold and conveyed subject to the easements, restrictions, covenants, conditions and provisions set out herein and in the Declaration.

002-50-0322

Except as hereby amended by the addition, annexation and merger of said Phase II, the Declaration is and shall remain in full force and effect.

IN WITNESS WHEREOF, Ponderosa Forest, Inc. has executed this First Amendment on this the 2nd day of ^{September} ~~August~~, 1983. *(sic)*

PONDEROSA FOREST, INC.

By: *[Signature]*
B. R. Cleveland, President

Acknowledgment

THE STATE OF TEXAS
COUNTY OF GALVESTON

This instrument was acknowledged before me on the 2nd day of ~~August~~ ^{September}, 1983 by B. R. Cleveland, President of Ponderosa Forest, Inc., a Texas corporation, on behalf of said corporation.

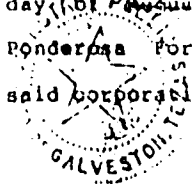

Ventura Rodriguez
NOTARY PUBLIC IN AND FOR
THE STATE OF TEXAS

VENTURA RODRIGUEZ
Notary Public in and for
the State of Texas
My Commission Expires 12-10-85

002-50-0323

DESCRIPTION OF A 46,188.01 SQUARE FOOT TRACT OUT OF LOTS 3, 4, and 5, SCHMIDT ENCLOSURE PARTITION, GALVESTON COUNTY, TEXAS

According to the map or plat recorded in Volume 76J, Page 624 in the Office of the County Clerk of Galveston County, Texas.

COMMENCING at the South corner of Lot 5, same being the East corner of Lot 4, said point lying in the Northwest right of way line of Sunset Street;

THENCE N $38^{\circ}12'$ W, along the common line between Lots 4 and 5, a distance of 935.36 feet;

THENCE S $51^{\circ}48'$ W, across Lots 4 and 3, a distance of 345.28 feet to the place of beginning of the tract hereinafter described, said beginning point lying in the Northeasterly right of way line of I.S. 45, 300 foot right of way;

THENCE from said beginning corner N $34^{\circ}10'50''$ W, along the Northeasterly right of way line of I. S. 45, 300 foot right of way, a distance of 96.64 feet to a point for corner;

THENCE N $51^{\circ}40'00''$ E, a distance of 203.50 feet to a point for corner;

THENCE N $38^{\circ}12'00''$ W, a distance of 81.00 feet to a point for corner;

THENCE N $27^{\circ}14'19''$ E, a distance of 73.41 feet to a point for corner;

THENCE N $24^{\circ}43'50''$ W, a distance of 20.00 feet to a point for corner;

THENCE S $63^{\circ}46'13''$ E, a distance of 252.08 feet to a point for corner;

THENCE S $54^{\circ}48'$ W, a distance of 390.28 feet to the place of beginning and containing 46,188.01 square feet, more or less.

PONDEROSA FOREST CONDOMINIUMS

PHASE TWO

EXHIBIT F

002-50-0324

PONDEROSA FOREST CONDOMINIUMS
PERCENTAGE OWNERSHIP INTEREST IN COMMON ELEMENTS

PHASE I
BUILDING A

<u>UNIT NO.</u>	<u>PERCENTAGE OWNERSHIP INTEREST</u>
1	1.43
2	1.43
3	2.21
4	2.21
5	2.21
6	2.21
7	1.43
8	1.43
9	1.43
10	1.43
11	2.21
12	2.21
13	2.21
14	2.21
15	1.43
16	1.43

BUILDING B

<u>UNIT NO.</u>	<u>PERCENTAGE OWNERSHIP INTEREST</u>
269	1.54
270	1.54
271	1.56
272	1.56
273	1.54
274	1.54
275	1.54
276	1.54
277	1.56
278	1.56
279	1.54
280	1.54

02-50-0325

PHASE II
BUILDING C

<u>UNIT NO.</u>	<u>PERCENTAGE OWNERSHIP INTEREST</u>
257	1.98
258	1.98
259	1.98
260	1.98
261	1.72
262	1.98
263	1.72
264	1.98
265	1.98
266	1.72
267	1.98
268	1.72

BUILDING D

<u>UNIT NO.</u>	<u>PERCENTAGE OWNERSHIP INTEREST</u>
241	1.98
242	1.98
243	1.98
244	1.98
245	1.72
246	1.72
247	1.72
248	1.72
249	1.98
250	1.98
251	1.98
252	1.98
253	1.72
254	1.72
255	1.72
256	1.72

TOTAL PERCENTAGE 100.00%

012-50-0326

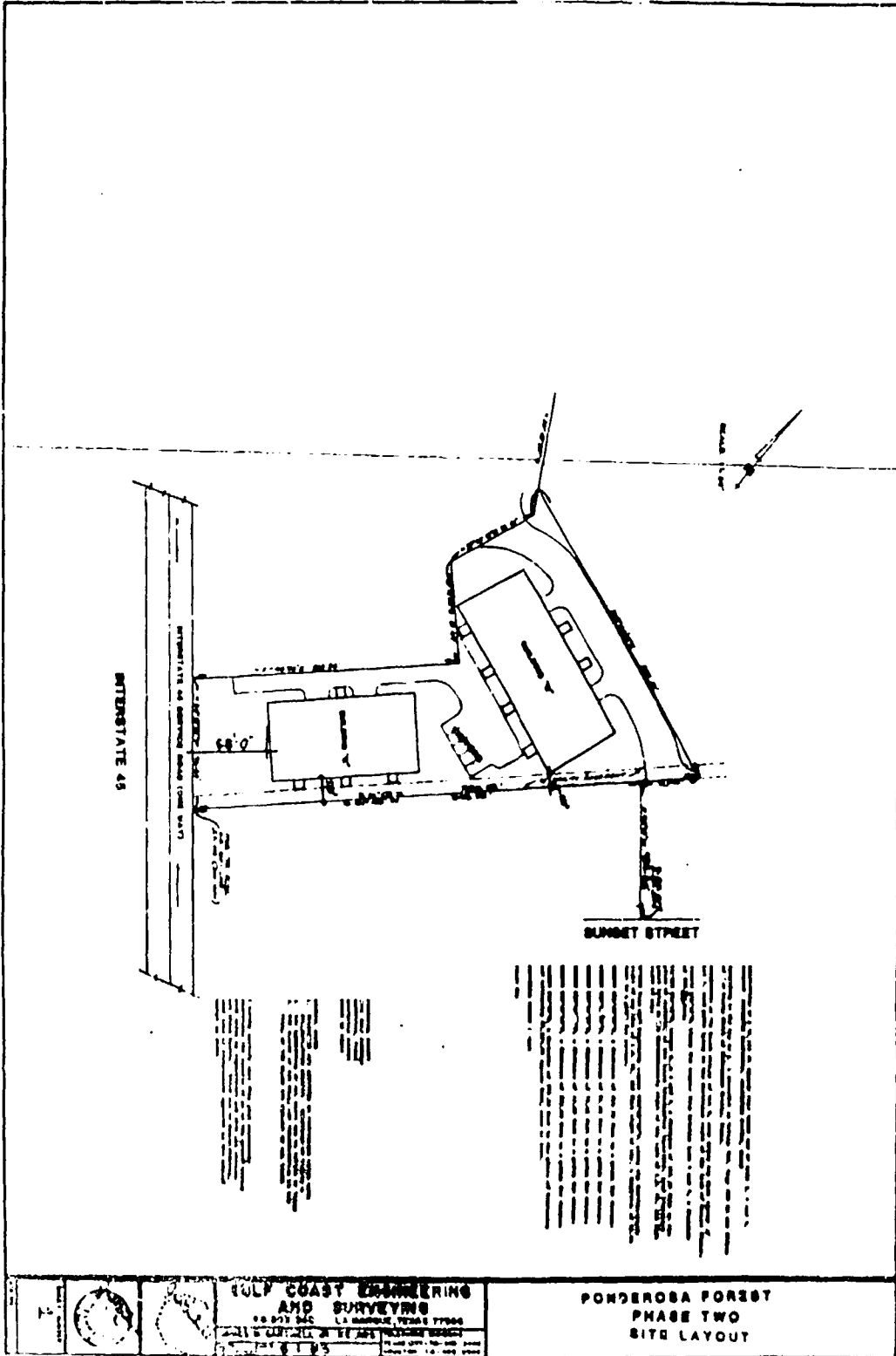

REVISIONS
NO. 1
DATE
DESCRIPTION

PLAN
NO. 1
DATE
DESCRIPTION

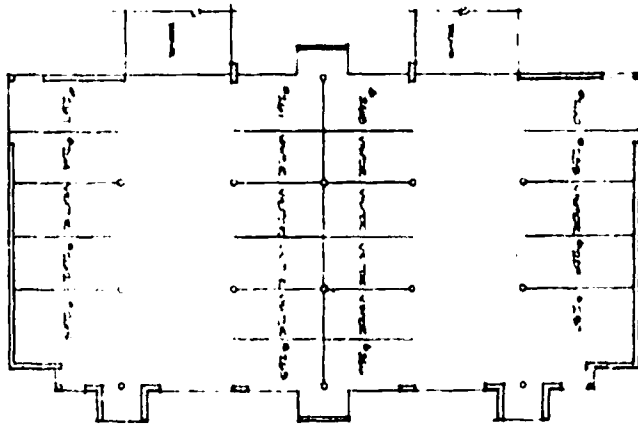

2			GULF COAST ENGINEERING AND SURVEYING 200 N. 14th St. LA MARQUE, TEXAS 77644 L. A. MARQUE, TEXAS 77644 L. A. MARQUE, TEXAS 77644	PONDWATER FOREST PHASE TWO
---	--	--	--	---

002-50-0328

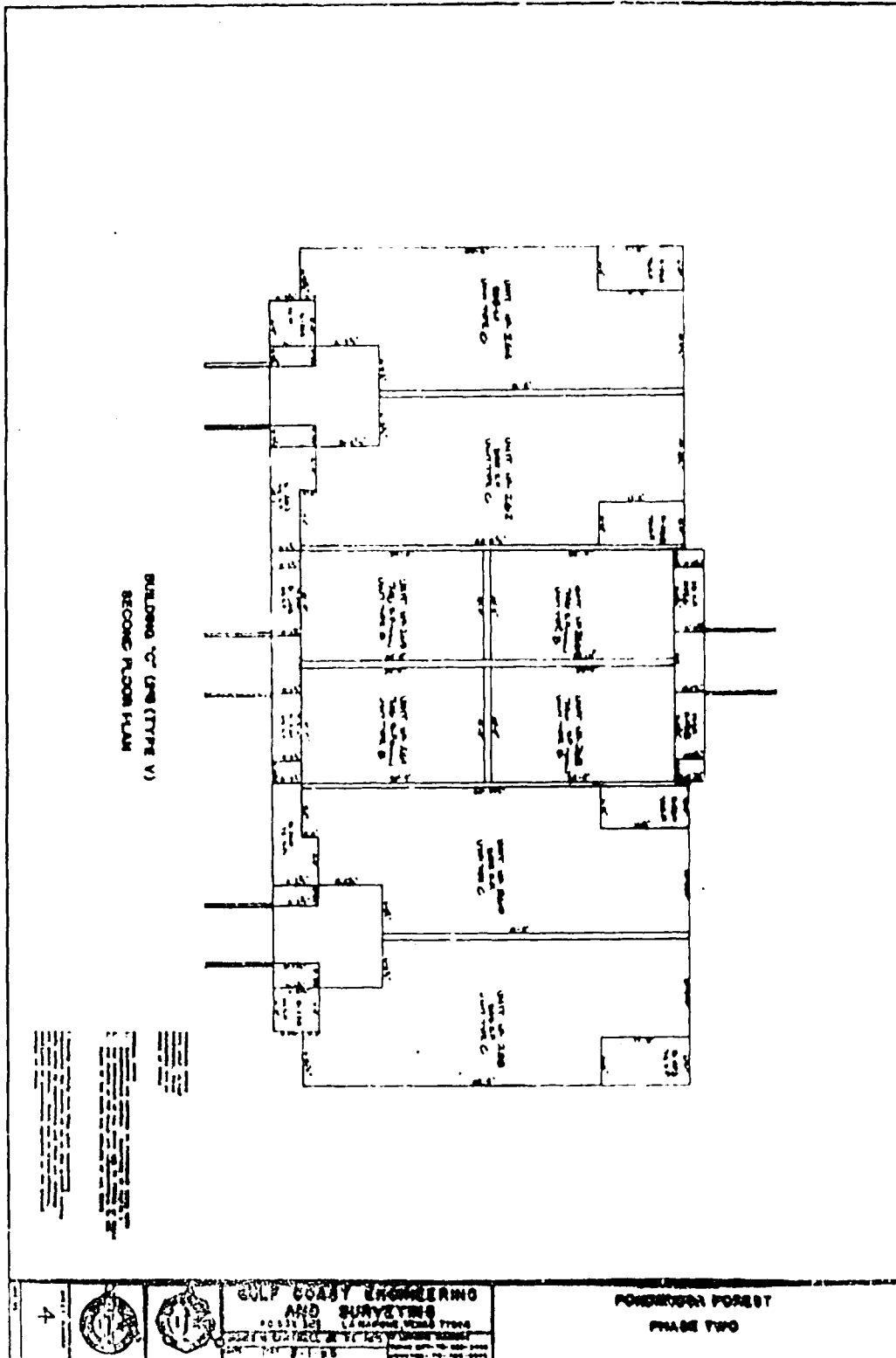

002-50-0329

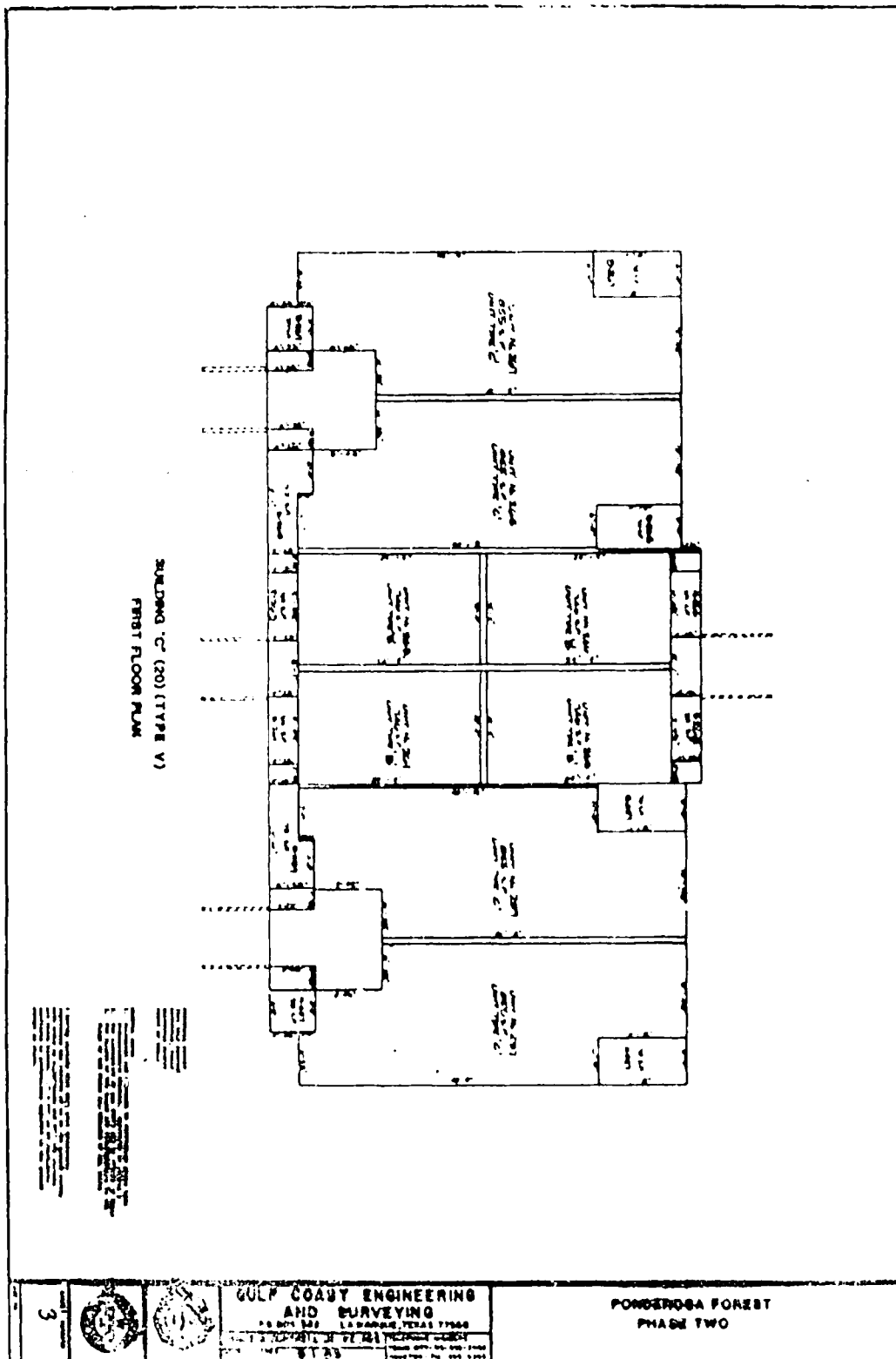

002-50-0330

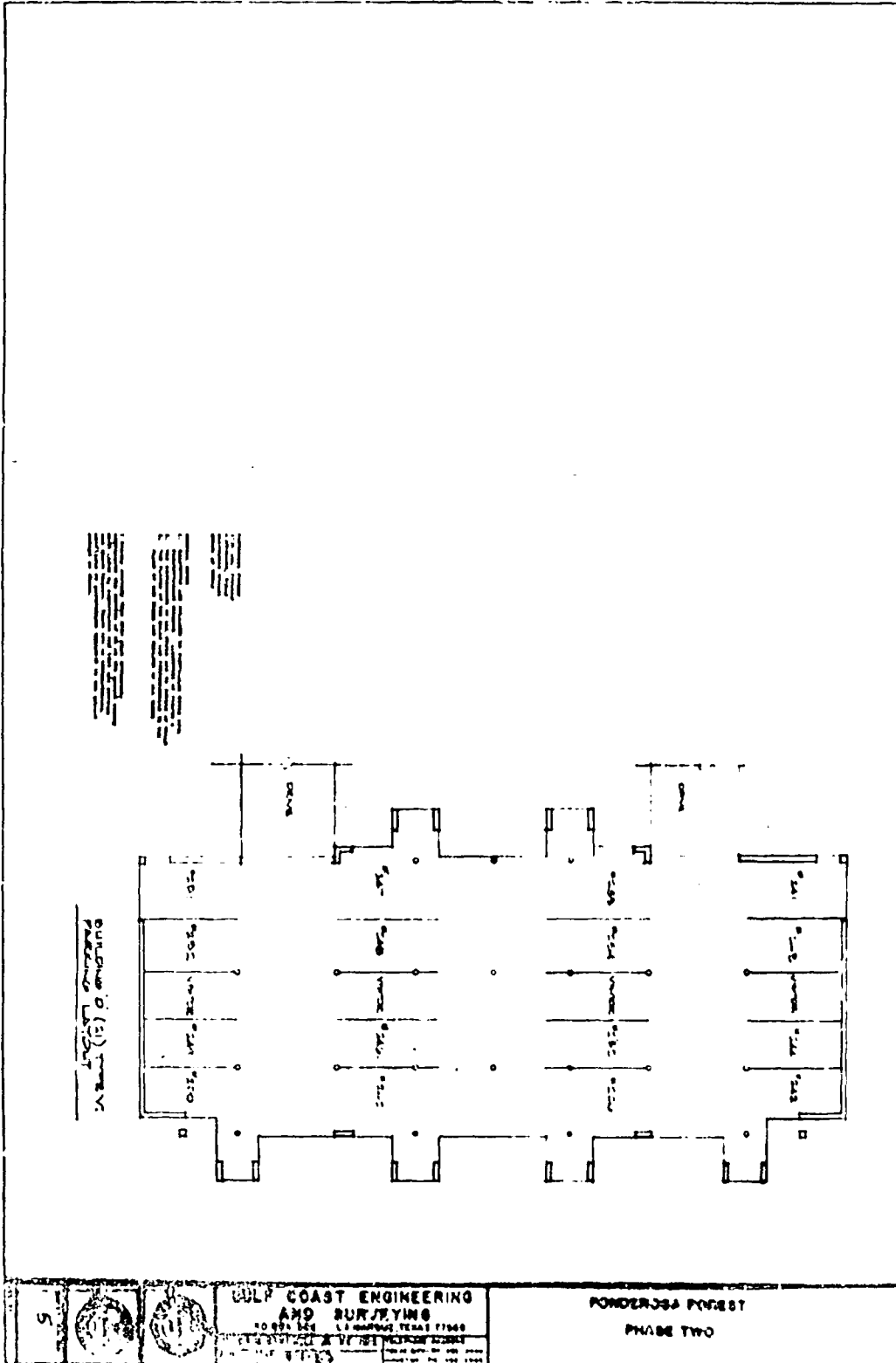

002-50-0331

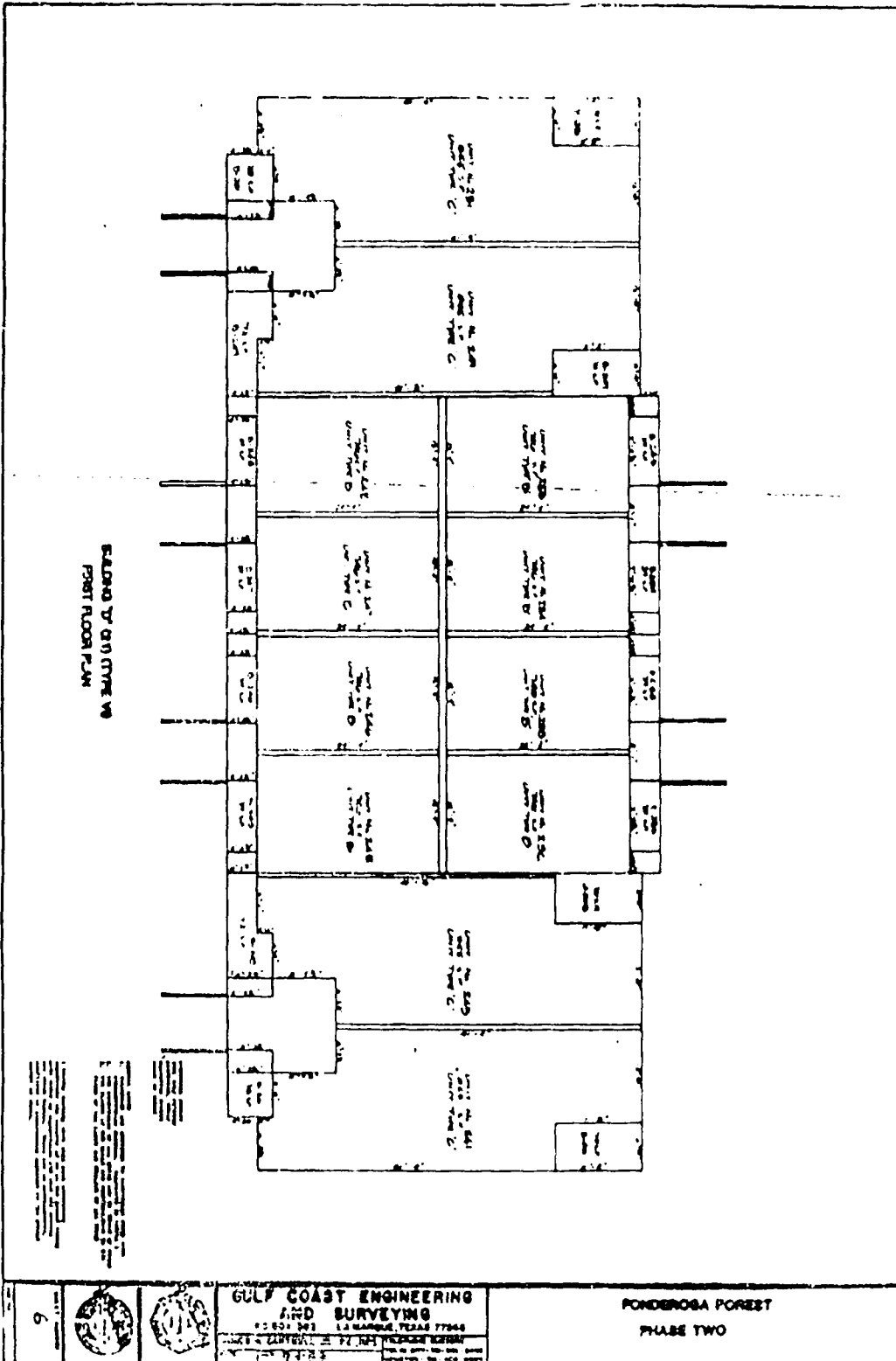

002-50-0332

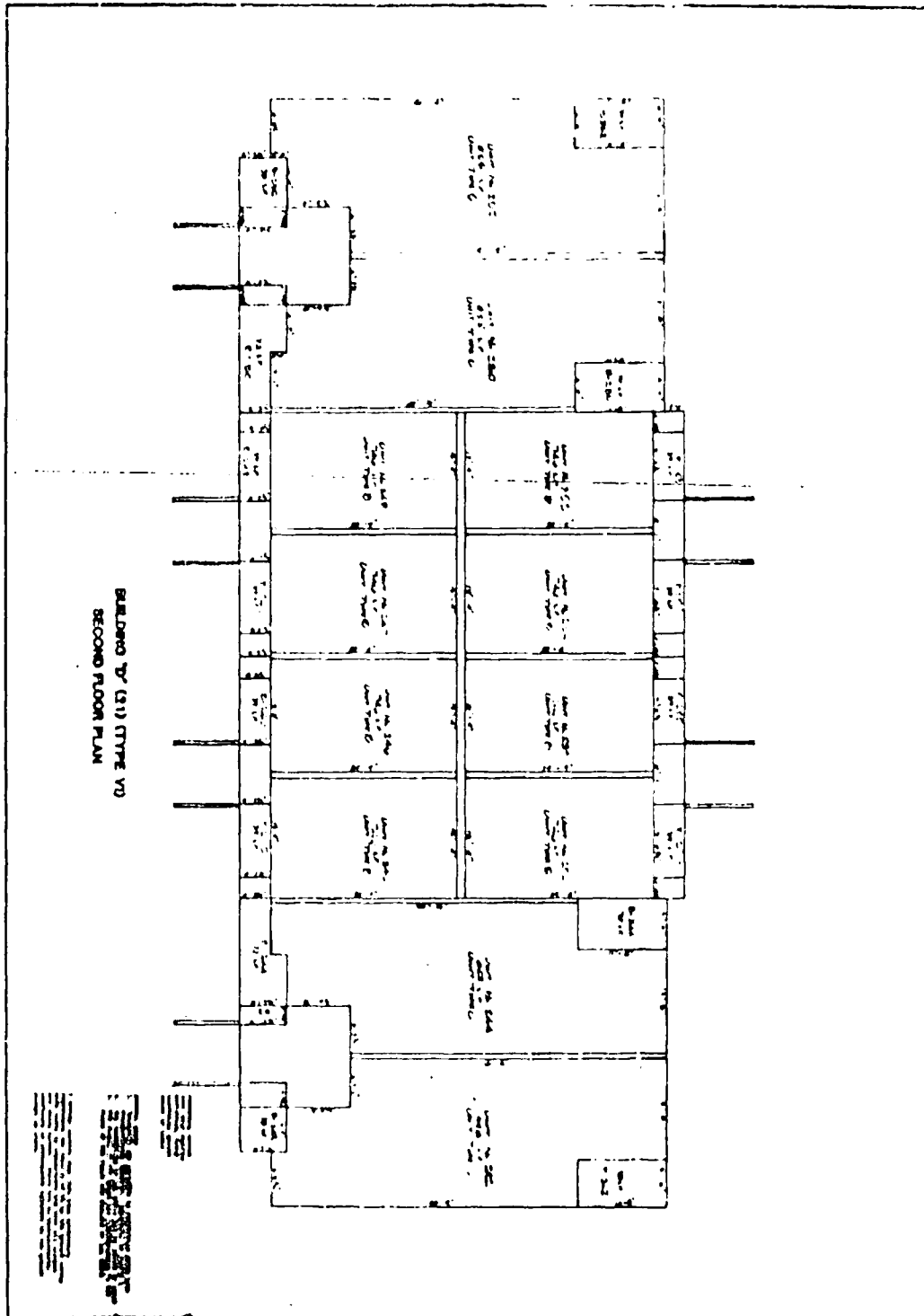

BUILDING 7 (11) TYPE V3
SECOND FLOOR PLAN

7			GOLY GULY ENGINEERING AND SURVEYING	PONDEROSA FOREST
			59 451 152 1000 10th Street, Suite 100 Tulsa, Oklahoma 74103 Phone: 918-439-1100 Fax: 918-439-1101	PHASE TWO

8438489

HF#17492

003-27-0742

SECOND AMENDMENT TO DECLARATION
AND MASTER DEED FOR
PONDEROSA FOREST CONDOMINIUMS

This amendment is made and entered into by Ponderosa Forest, Inc., a Texas corporation hereinafter referred to as "Declarant" on the date noted below.

W I T N E S S E T H

WHEREAS, PONDEROSA FOREST CONDOMINIUMS was established by the recordation of a Declaration and Master Deed for Ponderosa Forest Condominiums on the 8th day of August, 1983 at film code number 002-47-2292 of the Condominiums Records of Galveston County, Texas, said document hereinafter referred to as the "Declaration," and all other terms used herein shall have the same meaning and definition used or provided said terms in the Declaration;

WHEREAS, the Declaration provides for common elements as follows:

2.1.2 Common Elements This remaining portion of the Property, referred to herein as "Common Elements" shall include all of the elements set forth in Section 1.6. Each Unit shall have as an appurtenance to it an undivided percentage interest in the Common Elements, based upon the approximate size of the Unit in relation to the others, as set forth in Exhibit "C" attached hereto and by this reference made a part hereof. The ownership of each Condominium shall include a Unit and such undivided percentage interest in the Common Elements. Such Common

Return to:

Ponderosa Forest
P.O. Drawer 1245
Friendswood TX 77546

FILED

003-27-0743

Interest cannot be separated from the Unit to which it is appurtenant. Each Unit Owner shall have a non-exclusive right to use the General Common Elements in accordance with the purposes for which they are intended without hindering the exercise of or encroaching upon the rights of any other Unit Owners. Notwithstanding the transfer of the ownership of the Common Elements to the Owners as tenants in common, the Declarant shall reserve and hereby reserves unto itself and to the Association or its designated agents an easement over and onto the Common Elements for common driveway purposes, for drainage and encroachment purposes and for ingress to and egress from the Common Elements for the purpose of completing improvements thereon and for the performance of necessary repair work. Declarant further reserves unto itself and to the Association or its designated agents the right to establish easements, reservations, exceptions and exclusions consistent with the ownership of the Condominium Project and for the best interest of the Owners and the Association in order to serve the entire Condominium Project. Declarant further reserves unto itself and to the Association or its designated agents the right to grant easements of ingress and egress over and onto the common driveways.

WHEREAS, Declarant is presently the owner of more than 67% of all the Units in Ponderosa Forest Condominiums and the owner of the real property described in Exhibit A.

NOW, THEREFORE, Declarant hereby amends the above set-forth paragraph designated as paragraph 2.1.2 Common Elements to read and be as follows:

2.1.2 Common Elements The remaining portion of the Property, referred to herein as "Common Elements" shall include all of the elements set forth in Section 1.6. Each Unit shall have as an appurtenance to it an undivided percentage interest in the Common Elements, based upon the approximate size of the Unit in relation to the others, as set forth in Exhibit "C" attached hereto and by this reference made a part hereof. The ownership of each

003-27-0744

Condominium shall include a Unit and such undivided percentage interest in the Common Elements. Such Common Interest cannot be separated from the Unit to which it is appurtenant. Each Unit Owner shall have a non-exclusive right to use the General Common Elements in accordance with the purposes for which they are intended without hindering the exercise of or encroaching upon the rights of any other Unit Owners. Notwithstanding the transfer of the ownership of the Common Elements to the Owners as tenants in common, the Declarant shall reserve and hereby reserves unto itself and to the Association or its designated agents an easement over and onto the Common Elements for common driveway purposes, for drainage and encroachment purposes and for ingress to and egress from the Common Elements for the purpose of completing improvements thereon and for the performance of necessary repair work. Declarant further reserves unto itself and to the Association or its designated agents the right to establish easements, reservations, exceptions and exclusions consistent with the ownership of the Condominium Project and for the best interest of the Owners and the Association in order to serve the entire Condominium Project. Declarant further reserves unto itself and to the Association or its designated agents the right to grant easements of ingress and egress over and onto the common driveways.

Except as heretofore amended and hereby amended the Declaration is and shall remain in full force and effect.

IN WITNESS WHEREOF, Ponderosa Forest, Inc. has executed this Second Amendment on this the 31st day of July, 1984.

PONDEROSA FOREST, INC.

By:

Carole D. Baker
Carole D. Baker, Secretary

8822861

005-92-2052

THIRD AMENDMENT TO DECLARATION
AND MASTER DEED FOR
PONDEROSA FOREST CONDOMINIUMS

This Amendment is made and entered into by Stanislaw Kostek, hereinafter referred to as "Declarant", on the date noted below.

WITNESSETH

WHEREAS, PONDEROSA FOREST CONDOMINIUMS was established by the recordation of a Declaration and Master Deed for Ponderosa Forest Condominiums on the 8th day of August, 1983 at film code number 002-47-2292 of the Condominiums Records of Galveston County, Texas, said document hereinafter referred to as the "Declaration," and all other terms used herein shall have the same meaning and definition used or provided said terms in the Declaration;

WHEREAS, the Declaration provides for control of the Association as follows:

"3.14 Control of the Association Paragraph 3.1 notwithstanding and for the benefit and protection of the Owners and any Institutional Lenders of record and for the sole purpose of insuring a complete and orderly buildout as well as a timely sellout of the Condominiums, including any annexations of future phases as provided in Paragraph 2.4, the Declarant's control of and over the Association shall not to exceed July 1, 1988; a date one hundred twenty (120) days from the sale of seventy-five percent (75%) of the Units, including any annexations, or when in the opinion of the Declarant the entire Project including all

005-92-2069

annexations becomes viable, self-supporting and operational, whichever occurs first. In no event shall Declarant's control extend beyond July 1, 1988, if all proposed phases are annexed and incorporated hereinto by merger. Within sixty (60) days after the date on which the Declarant's control of the Association ends, as specified herein, the Declarant, through the Board of Directors, shall call the first annual meeting of the Association."

WHEREAS, the first annual meeting of the Association has not yet been held, and Declarant is presently the owner of more than 71% of all the Units in Ponderosa Forest Condominiums;

NOW, THEREFORE, Declarant hereby amends the above set forth paragraph designated as paragraph 3.14 Control of the Association to read and be as follows:

"3.14 Control of the Association Paragraph 3.1 notwithstanding and for the benefit and protection of the Owners and any Institutional Lenders of record and for the sole purpose of insuring a complete and orderly buildout as well as a timely sellout of the Condominiums, including any annexations of future phases as provided in Paragraph 2.4, the Declarant's control of and over the Association shall not extend beyond July 1, 1993; a date one hundred twenty (120) days from the sale of seventy-five percent (75%) of the Units, including any annexations; or when in the opinion of the Declarant the entire Project including all annexations becomes viable, self-supporting and operational, whichever occurs first. In no event shall Declarant's control extend beyond July 1, 1993, if all proposed phases are annexed

005-92-2070

and incorporated hereinto by merger. Within sixty (60) days after the date on which the Declarant's control of the Association ends, as specified herein, the Declarant, through the Board of Directors, shall call the first annual meeting of the Association."

Except as heretofore amended and hereby amended the Declaration is and shall remain in full force and effect.

IN WITNESS WHEREOF, Stanislaw Kostek has executed this Third Amendment on this the 25th day of June, 1988.

Stanislaw Kostek
Stanislaw Kostek

Acknowledgment

THE STATE OF NEW YORK

COUNTY OF Warren

This instrument was acknowledged before me on the 25th day of June, 1988 by Stanislaw Kostek.

Barbara A. Andrews
Notary Public in and for the
State of _____
County of _____
Printed Name: _____
My Commission expires: _____

BARBARA A. ANDREWS
NOTARY PUBLIC, STATE OF NEW YORK
WARREN COUNTY, # 49848
MY COMMISSION EXPIRES DEC. 31, 1991